

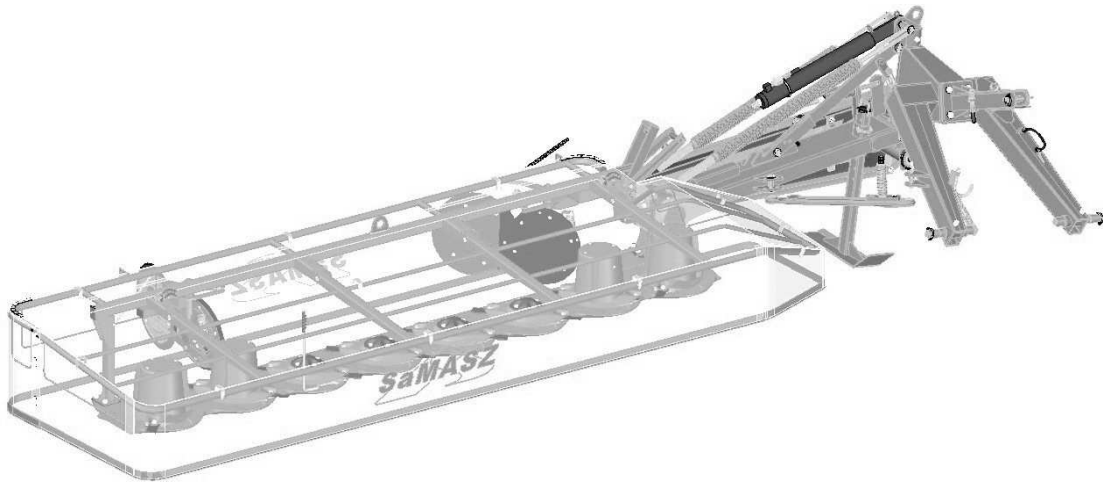

NIP PL-966-15-92-976  
tel. (+48) (85) 654-45-84  
fax (+48) (85) 664-70-41  
e-mail: samasz@samasz.pl  
[www.samasz.pl](http://www.samasz.pl)

## OPERATOR'S MANUAL



### REAR DISC MOWER

<b>KDT 180</b>	-	<b>1,8 m</b>
<b>KDT 220</b>	-	<b>2,2 m</b>
<b>KDT 220 W</b>	-	<b>2,2 m</b>
<b>KDT 220 S</b>	-	<b>2,2 m</b>
<b>KDT 260</b>	-	<b>2,6 m</b>
<b>KDT 260 W</b>	-	<b>2,6 m</b>
<b>KDT 260 S</b>	-	<b>2,6 m</b>
<b>KDT 300</b>	-	<b>3,0 m</b>
<b>KDT 340</b>	-	<b>3,4 m</b>

Serial No:

**IN221EN009**  
**09.06.2014**  
**EDITION NR 9**

*The original instruction*

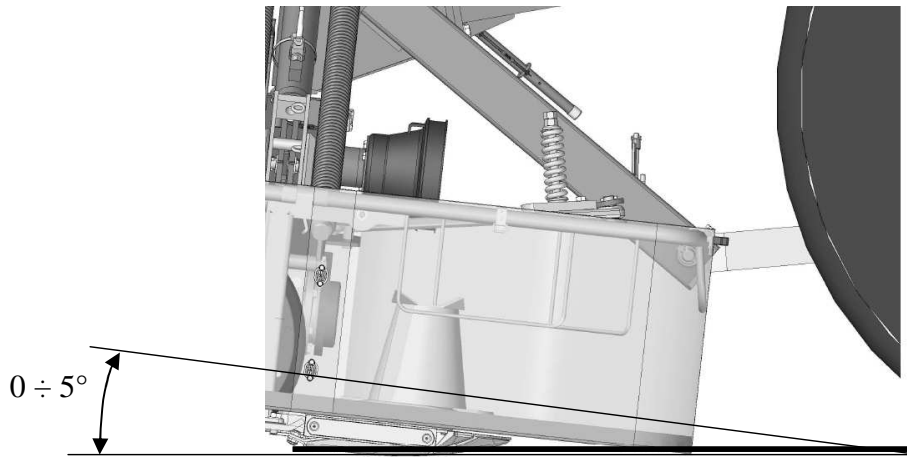

Optimum inclination towards the ground is  $0 \div 5^\circ$   
to the mowing direction  
It is allowed to work in horizontal position.  
Different inclination may damage the mower.



**DO NOT**  
TURN THE DRIVE ON  
IF THE MOWER IS NOT IN  
WORKING POSITION



**DO NOT**  
LIFT THE MOWER  
BEFORE THE MOWING  
DISCS HAVE COME TO  
COMPLETE STANDSTILL



**DO NOT**  
OPERATE WHEN ANY  
PERSON REMAINS IN THE  
DANGER AREA OF 50 m



**CAUTION:**  
Keep this manual for future reference.

<b>1. IDENTIFYING THE MACHINE</b> .....	<b>2</b>
<b>2. INTRODUCTION</b> .....	<b>2</b>
<b>3. PROPER USE</b> .....	<b>3</b>
3.1. Technical data .....	4
3.2. Design and working principle .....	5
3.3. Standard equipment and spare parts.....	6
<b>4. SAFETY ADVICE</b> .....	<b>7</b>
4.1. Safety rules and regulations .....	7
4.2. Transport .....	9
4.2.1. Putting the mower onto another vehicle for transport .....	10
4.3. Working parts.....	11
4.4. PTO shaft .....	11
4.5. Residual risk.....	12
4.5.1. Danger of catching .....	12
4.5.2. Danger of injury .....	12
4.5.3. Danger of liquid ejection out of hydraulic system .....	13
4.5.4. Bans.....	13
4.5.5. Residual risk evaluation .....	13
4.6. Warning decals and their meaning.....	14
<b>5. OPERATION</b> .....	<b>17</b>
5.1. Attaching the mower to the tractor .....	17
5.2. Preparing the mower for transport .....	18
5.3. Preparing the mower for transport on public roads.....	19
5.4. Mounting PTO shaft .....	19
5.5. Switching from transport to working position .....	20
5.6. Preparing the mower for work .....	21
5.7. Operation (mowing).....	22
5.7.1. Essential information concerning mowing.....	22
5.7.2. Design and and operation of safety breakaway device .....	23
5.7.3. Mower clogging .....	23
5.7.4. Taking turns over swaths.....	23
<b>6. MOUNTING AND ADJUSTMENTS</b> .....	<b>24</b>
6.1. Mounting and timing of the knives .....	24
6.2. Replacing the knives .....	25
6.3. Adjusting the cutterbar.....	25
6.4. Adjusting the cutting height.....	28
6.5. 3-point linkage support chain.....	28
6.6. Adjusting the space between tine conditioner's mask and its shaft .....	29
6.7. Replacing the conditioner's tines.....	29
6.8. Adjusting force of the prssure of roller conditioner.....	30
6.9. Maintenance and service.....	30
6.9.1. Checking the knives and knife holders.....	30
6.9.2. Checking the V-belts tension .....	31
6.9.3. Checking the tension of tine and roller conditioners' driving chain .....	31
6.9.4. Daily maintenance.....	32
6.9.5. After-season maintenance and storing of machine.....	32
<b>7. LUBRICATION</b> .....	<b>33</b>
7.1. Cutterbar .....	33
7.2. Intersecting axis gear .....	33
7.3. Roller conditioner's gearbox.....	34
7.4. Bearings and joints.....	35
<b>8. DEFECTS AND THEIR REPAIRS</b> .....	<b>35</b>
<b>9. DISASSEMBLY AND WITHDRAWAL FROM USE</b> .....	<b>37</b>
9.1. Disassembly .....	37
9.2. Scrapping .....	37
<b>10. WARRANTY CARD</b> .....	<b>37</b>
<b>11. WARRANTY TERMS</b> .....	<b>38</b>
11.1. Warranty claims procedures.....	38
11.2. Warranty repairs record .....	39

## 1. IDENTIFYING THE MACHINE

Data plate is mounted to the mower's main frame in the place shown below (**Fig. 1**).



**Fig. 1.** Data plate place



**Fig. 2.** Data plate

Data plate includes:

- name of the manufacturer,
- mower's number,
- mower's type,
- manufacturing date,
- version number,

- weight,
- quality management sign,
- CE sign,
- MADE IN POLAND sign,
- barcode.



### **CAUTION:**

For more detailed information concerning the mower ask your dealer or manufacturer.

## 2. INTRODUCTION

- This operator's manual should be considered as the basic mower's equipment. If the mower is handed over to another operator, it should be in working condition and given away along with operator's manual and it's other basic equipment.
- Operator's manual is attached to every machine in order that the operator can familiarize himself with design, working principles, service and adjustment of the mower. The user of the mower should be familiar with common safety rules and procedures.
- The mower is manufactured according to international safety rules.
- Compliance with the warnings in this operator's manual will ensure safe operation.
- Please contact your dealer if you have any queries relating to the operation and service of the mower.
- Operator's manual remains part of mower's equipment.



### **GENERAL WARNING**

When operating the mower please comply with the warnings and safety regulations shown throughout this manual by this safety alert symbol.



### **CAUTION:**

Operation of the mower before reading the operator's manual carefully as well as operating by the unauthorized staff, especially by children, is strictly forbidden.

### 3. PROPER USE

1. Mower KDTC is equipped with "**Perfect Cut**" cutterbar. **Table 1** shows the differences in mowing height depending on angle at which cutterbars are set and what kind of skids are applied.

**Tab. 1.** Mowing height depending on the kind of the cutting bar and its tilt angle

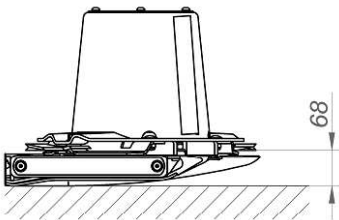
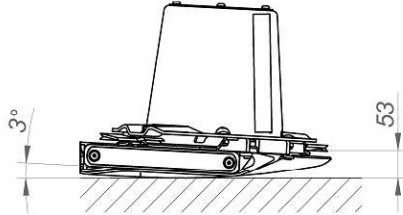
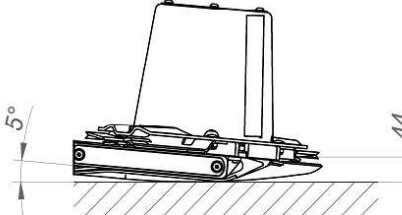
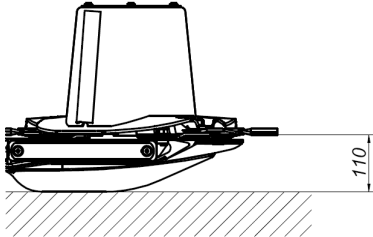
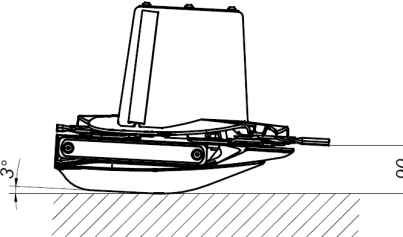
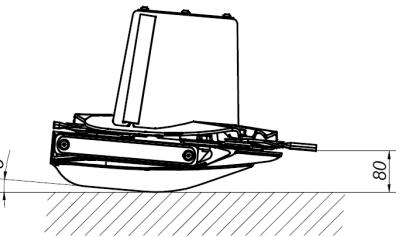
„Perfect Cut” cutting bar		
No tilt	3° tilt	5° tilt
<b>Standard mowing height</b>		
		
<b>Optional height with using topping skid</b>		
		

- The rear mounted disc mower is intended to mow green fodder: grass, alfalfa and such on permanent grassland (pastures), on crop fields without rocks, and to form loose rows of cut fodder. The pasture or field being mown should be even, best if prepared by rolling. In the event of a majority of tall grass the first and second mowing should be done at a height of 60 - 70 mm, while with a majority of short grasses at a height of 50 mm. The last mowing should be done a little higher - at 70 - 80 mm from the ground.
1. A mower with the crop scarifier/rollers is equipped with the „Perfect Cut” cutting bar.
    - The rear mounted disc mower with crop scarifier/rollers is intended to mow green fodder: grass, alfalfa and such on permanent grassland (pastures), on crop fields without rocks, and to form loose rows of cut fodder. As a result of the passing of the layers of the green fodder through the flails or rollers the grass stems are broken and a layer of wax is removed. This facilitates and speeds up the drying process of the fodder by approximately 30 to 40%. The use of rollers is especially recommended when mowing legumes such as alfalfa. Rollers are particularly recommended for mowing grass legume such as alfalfa. The pasture or field being mown should be even, best if prepared by rolling. This is especially true of mowers with rollers as they tolerate rocks with a diameter of a few centimeters. If a larger stone is picked up stop and remove it as it could cause damage of the discs. With a majority of tall grasses the first and second mowing should be done at a height of 6 - 7 cm, while with a majority of short grasses at a height of 5 cm. The last mowing should be done a little higher - at 7 - 8 cm from the ground.

**CAUTION:**

Use of the mower for other purposes than the above mentioned is forbidden. Different use than the above mentioned will be considered as improper and may lead to revoking of the warranty. Mower should be used, operated and repaired only by people familiarised with its detailed specifications and with safety rules and regulations. Wilful changes of the mower will lead to revoking of the warranty.

### 3.1. Technical data

**Tab. 2. Specifications**

Model:	<b>KDT 180</b>	<b>KDT220</b>	<b>KDT260</b>	<b>KDT300</b>	<b>KDT340</b>
Working width	1.80 m	2.20 m	2.60 m	3.00 m	3.40 m
Number of knives [pcs.]	8 (2 x 4)	10 (2 x 5)	12 (2 x 6)	14 (2 x 7)	16 (2 x 8)
Tractor PTO rpm	540 rpm				
Tractor power required	22 kW (30 HP)	30 kW (50 HP)	50 kW (70 HP)	60 kW (80 HP)	75 kW (100 HP)
Tractor class	0.6	0.6	0.9	1.4	2.0
Working capacity	~ 2.0 ha/h	~ 2.5 ha/h	~ 3.0 ha/h	~ 3.5 ha/h	~ 4.0 ha/h
Transport length	1200 mm				
Transport width	1850 mm	2150 mm	2150 mm	2150 mm	2235 mm
Working width	3500 mm	4200 mm	4600 mm	5100 mm	5550 mm
Transport height	-	-	-	3750 mm	4200 mm
Weight	550 kg	670 kg	725 kg	785 kg	825 kg
PTO shaft with overrunning clutch requirement	400 Nm		540 Nm		
Cutting speed of the knife	91 m/s				
Disc rpm	3250 rpm				
Noise level $L_{pA}$	101 ± 1 dB				
$L_{Amax}$	113 ± 1 dB				
$L_{Cpeak}$	116 ± 1 dB				

Model	<b>KDT 220 S</b>	<b>KDT 260 S</b>	<b>KDT 220 W</b>	<b>KDT 260 W</b>
Working width	2.20 m	2.60 m	2.20 m	2.60 m
Number of knives [pcs.]	10 (2 x 5)	12 (2 x 6)	10 (2 x 5)	12 (2 x 6)
Tractor PTO rpm	540 rpm			
Tractor power required	44 kW (60 HP)	66 kW (90 HP)	44 kW (60 HP)	66 kW (90 HP)
Tractor class	2,0	2,0	2,0	2,0
Working capacity	~ 2.0 ha/h	~ 2.8 ha/h	~ 2.0 ha/h	~ 2.8 ha/h
Transport length	1600 mm	1220 mm	1500 mm	1445 mm
Transport width	2150 mm	2150 mm	2150 mm	2220 mm
Working width	4200 mm	4680 mm	4200 mm	4700 mm
Weight	940 kg	995 kg	950 kg	1005 kg
PTO shaft with overrunning clutch requirement	400 Nm	540 Nm	400 Nm	540 Nm
Cutting speed of the knives	91 m/s			
Disc rpm	3250 rpm			
Noise level $L_{pA}$	98 ± 1 dB		97 ± dB	
$L_{Amax}$	109 ± dB			
$L_{Cpeak}$	112 ± dB			

S – Mower with tine conditioner

W – Mower with roller conditioner

- $L_{pA}$  – noise level related to 8 hour working time. Averaged in time acoustic pressure level corrected by frequency characteristic A.
- $L_{Amax}$  – maximum value corrected by frequency characteristic A of acoustic pressure level.
- $L_{Cpeak}$  – peak level of acoustic pressure corrected by frequency characteristic C.

### 3.2. Design and working principle

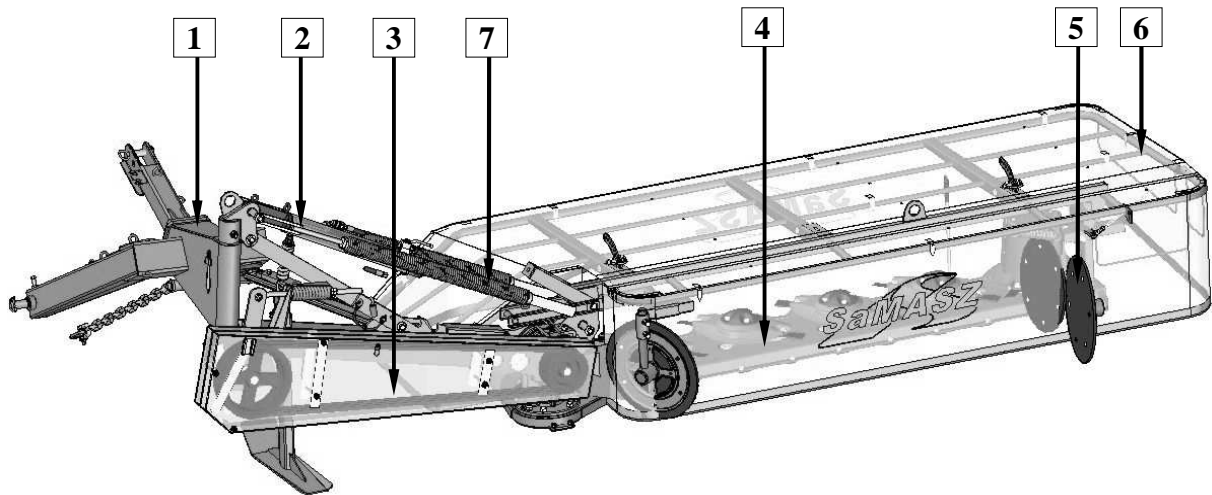

**Fig. 3a.** Parts of SaMASZ rear disc mower

- |                             |                     |
|-----------------------------|---------------------|
| 1 – 3-point linkage frame   | 4 – Cutterbar       |
| 2 – Hydraulic cylinder with | 5 – Swath discs     |
| 3 – Drive unit              | 6 – Safety curtain  |
|                             | 7 – Support springs |

3-point linkage frame (1) enables attachment of the mower to tractor's 3-point linkage. Drive from tractor's rpm is transmitted through drive unit (3) on the cutterbar (4). Hydraulic cylinder (2) is used to adjust the mower to working position. It is supplied from outer hydraulics of the tractor. Main frame, on which the cutterbar (4) is situated, is supported by the springs (7). Swath discs (5) are mounted on the main frame.

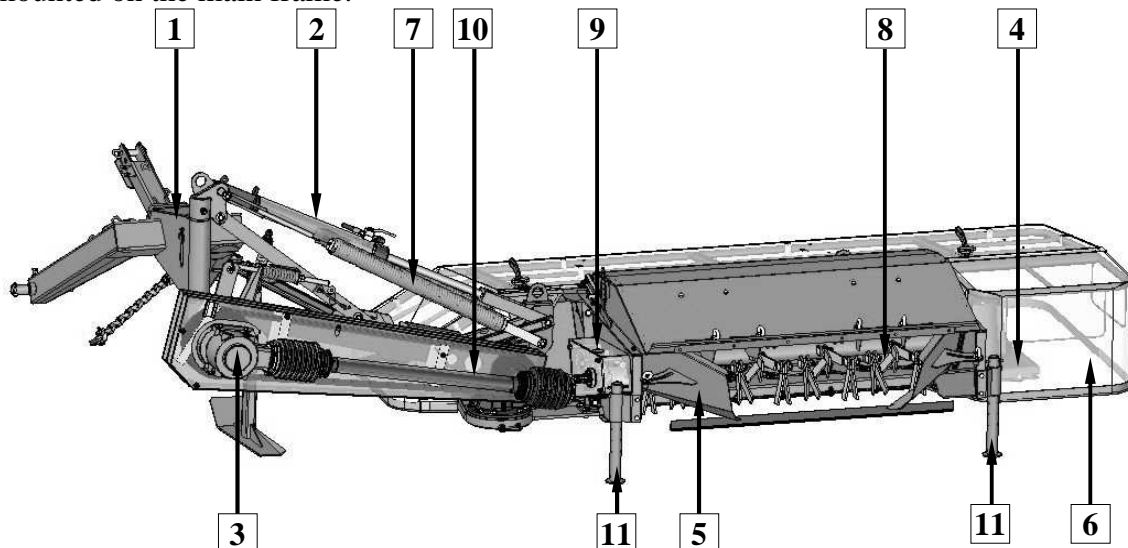

**Fig. 3b.** Parts of SaMASZ rear disc mower with tine conditioner

- |                             |                      |
|-----------------------------|----------------------|
| 1 – 3-point linkage frame   | 6 – Safety curtain   |
| 2 – Hydraulic cylinder with | 7 – Support springs  |
| 3 – Intersecting axis gear  | 8 – Tine conditioner |
| 4 – Cutterbar               | 9 – Chain gear       |
| 5 – Swath discs             | 10 – PTO shaft       |
|                             | 11 – Support legs    |

3-point linkage frame (1) enables attachment of the mower to tractor's 3-point linkage. Drive from tractor's rpm is transmitted through intersecting axis gear (3) on the cutterbar (4). On the cutterbar, there are discs with two knives each. Apart from that, drive from tractor's rpm through chain gear (9) and PTO shaft (10) is transmitted to tine conditioner (8). Hydraulic cylinder (2) is used to adjust the mower to working position. It is supplied from outer hydraulics of the tractor. Main frame, on which the cutterbar (4) is situated, is supported by the springs (7). Swath guides (5) are mounted on the main frame.

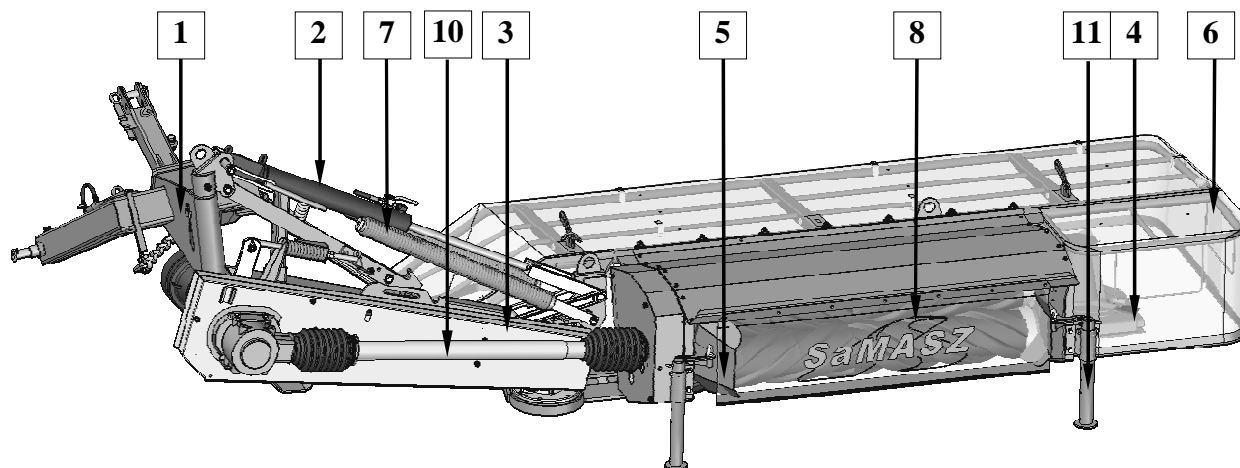

**Fig. 3c.** Parts of SaMASZ rear disc mower with tine conditioner

- |   |                        |
|---|------------------------|
| 1 – 3-point linkage frame                   | 6 – Safety guard       |
| 2 – Hydraulic cylinder with support springs | 7 – Springs            |
| 3 – Intersecting axis gear                  | 8 – Roller conditioner |
| 4 – Cutterbar                               | 9 – Chain gear         |
| 5 – Swath guides                            | 10 – PTO shaft         |
|   | 11 – Support legs      |

3-point linkage frame (1) enables attachment of the mower to tractor's 3-point linkage. Drive from tractor's rpm is transmitted through intersecting axis gear (3) on the cutterbar (4). On the cutterbar, there are disco with two knives each. Apart from that, drive from tractor's rpm through Intersecting axis gear (3) and PTO shaft (10) is transmitted to roller conditioner (8). Hydraulic cylinder (2) is used to adjust the mower to working position. It is supplied from outer hydraulics of the tractor. Main frame, on which the cutterbar is situated, is supported by the springs (7). Swath guides (5) are mounted on the main frame.

*Well-proven design with thousands of machines in regular use in many countries and quality materials ensure high durability and reliability of SaMASZ mowers.*

### 3.3. Standard equipment and spare parts

The mowers are sold with the following standard equipment:

- warranty card,
- operator's manual with spare parts list,
- cutting knives: additional set,
- PTO shaft with overrunning clutch,
- spray paint (150 ml).

#### **Optional extra equipment:**

- warning plate with combined lights and reflectors,
- warning triangle.



**Tab. 3.** PTO shaft for rear disc mower

Model	Power	Length	Moment	Symbol	Clutch	Producent	Uwagi
	KM	mm	Nm				
KDT 220; KDT 260 KDT 300; KDT 340 KDT 220 S/W KDT 260 S/W	35	910-1275	460	7G4N091CE007096MA	Overrunning right	BONDIOLI & PAVESSI	
KDT 180	21	860-1208	270	7G2N086CE007096M	Overrunning right	BONDIOLI & PAVESSI	

PTO shaft's end without clutch – To be mounted on the tractor's side.

PTO shaft's end with overrunning clutch – To be mounted on mower's side

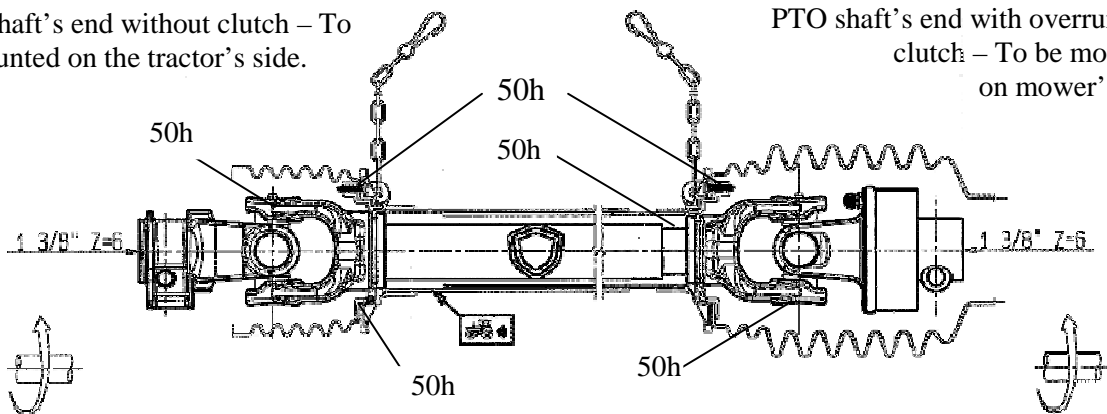

**Fig. 4.** PTO shaft lubrication points. Mounting directions



**CAUTION:**

Lubricate the PTO shaft with high quality multi-purpose grease every 50 shaft operating hours. If access holes are available, lubricate fittings through access holes.

PTO shafts of other brands with equivalent parameters could be used after SaMASZ permission.



**CAUTION:**

Optional extra equipment should be ordered separately.

The mower is equipped with such elements as holders and brackets used to mount warning lights and plates. Combined lights and reflectors are mounted on the warning plates.

*We congratulate you on the purchase of your new SaMASZ mower and wish you much pleasure and the very best work results through the years to come.*

**4. SAFETY ADVICE**

**4.1. Safety rules and regulations**

- ❑ Front axis of the tractor should be weighted to keep the balance. If need be, use front wheel weights.
- ❑ Any operation with the hydraulic lift lever should be done from the operator's seat; **DO NOT** move the lever from outside of the tractor.  
 In case of tractors equipped with EHR, operating with hydraulic lift is done by the buttons mounted outside the tractor's cabin. When operating be extremely careful.
- ❑ When switching from working to transport position unmount the whole or at least one end (from tractor's PTO) of PTO shaft.

- ❑ Operation without safety guards as well as with the damaged or raised guards is not allowed (danger of the stones, etc. being thrown out). Damaged protective apron should be replaced with a new one.
- ❑ When operating the mower, control damages to structures, protective aprons, chains, rubber elements and if need be, replace these with new ones, even not completely worn out elements.
- ❑ Start mowing only when the tractor's PTO reaches its normal 540 rpm.
- ❑ DO NOT exceed 600 PTO rpm.
- ❑ Nobody is allowed to remain within the danger area of at least 50 m. Particular caution is necessary when operating near roads and in stoney areas.
- ❑ Do not remain on the mower when operating.
- ❑ Any maintenance and adjustment work should only be done after the drive has been disconnected and when the cutting discs have come to the complete standstill.
- ❑ Always check the mower before starting work, in particular for damaged, missing and/or worn knives and knife holders. Damaged or worn parts must be replaced.
- ❑ When driving on public roads always comply with local traffic regulations, especially concerning warning lights.



**CAUTION:**

All service and repair operations must be done only after the tractor engine has been stopped, all rotating parts have come to the complete standstill and the cutterbar is on the ground.



**CAUTION:**

Be certain that children and animals are at a safe distance away from the machine. Never allow anyone to ride on a machine or tractor.

- ❑ When the mower is lifted for repair on the 3-point linkage, it should be secured against falling by a mechanical support or by chain.
- ❑ The bolts and other fasteners have to be periodically checked and, if necessary, tightened or replaced. DO NOT work with damaged or worn fasteners.
- ❑ Never lift the mower on tractor linkage when the drive is on and the cutting discs are rotating.
- ❑ During operation of the mower the Regulation of the Farm Ministry and Food Economy (Rozporządzenie Ministra Rolnictwa i Gospodarki Żywnościowej) from 12-01-1998 dealing with safety and hygiene during the operation of tractors, machinery, tools and equipment used for farming (Dz. U. Nr 12/98 poz. 51), should be observed,
- ❑ When operating the mower, the tractor should always be equipped with the cabin.
- ❑ Mower should not be operated when the tractor-mower set is not balanced.
- ❑ Never start the mower when it is lifted.
- ❑ Never start the mower, when people or animals are near the machine.
- ❑ Never lift the safety guard before the rotating parts have come to the complete standstill. Tractor's engine must be stopped. **Caution: Cutting knives keep rotating for several minutes after the engine is stopped.**
- ❑ Always comply with the safety decals describing hazards, and warning signs placed on the machine.
- ❑ Before you start the tractor make sure that every other drives are turned off and the levers steering hydraulics are in neutral position.
- ❑ When mounting the mower on a tractor, danger of wounding is present. It is recommended for the operator to wear protective gloves.

- ❑ In the event of fatal failure, please call for technical service, and if an accident (in this case: road accident) occurs, respect first aid rules and contact responsible authorities.
- ❑ Mower should be kept clean, so as to avoid danger of fire.
- ❑ Never leave the tractor's engine running without supervision. Before you leave the tractor, turn off the engine and put off the key from tractor's ignition switch.
- ❑ It is forbidden to operate the mower when driving backwards.
- ❑ Never get on the mower.
- ❑ Never lift the mower on tractor's 3-point linkage when the drive is on and the discs are rotating.
- ❑ Permissible inclination of the slope when working and during transport is 8°.
- ❑ Never stand between tractor and mower, before tractor-mower set is secured against moving by the tractor's brake.
- ❑ Every maintenance work and regulations can be done only when the mower is on the ground.
- ❑ If any maintenance work or regulation under lifted mower is needed, it must be secured against falling.
- ❑ When the parts of the mower need replacement, use only the original spare parts according to spare parts list.
- ❑ Pay particular attention to PTO shaft's guards and mower's and tractor's spline shaft guards. Never work with damaged guards.
- ❑ Hydraulic hoses should be periodically checked and if any damage occur or they expire, replace with new ones. Expiry period should not exceed 5 years.
- ❑ Never use scotch tape to repair hydraulic hoses.
- ❑ When connecting hydraulic hoses to tractor's hydraulic connectors make sure, that either tractor's or mower's hydraulic system is without pressure.
- ❑ When operating hydraulic system, always wear protective gloves and glasses. Leaking under pressure hydraulic oil (16 MPa) may permeate through the skin and cause infection. If it happens, immediately visit a doctor.
- ❑ The mower should be stored under roofed places and in the way that it will not harm people or animals.

## **4.2. Mounting mower onto tractor**

- ❑ Prior to the mounting operation, check whether the tractor's and the mower's hitch categories are compatible and make sure that tractor's hitch load is adequate for the machine aggregated.
- ❑ Prior to mounting the machine, examine technical condition of the mower's hitch assembly and tractor's 3-point linkage.
- ❑ Use only genuine pins and cotters to mount the mower on a tractor.

## **4.3. Transport**

- ❑ Every position change of the mower can only be done when there is nobody around (pay particular attention to children).
- ❑ For the transport period put warning plate with combined lights and reflectors and warning triangle on the mower.
- ❑ During transport always put the mower to transport position. See chapter 5.2.
- ❑ Before putting the mower to transport position make sure, that the tractor's PTO is turned off and all the rotating parts have come to complete standstill.
- ❑ Driving speed should always be adjusted to road conditions.
- ❑ Permissible speed is 25 km/h and it cannot be exceeded.

#### 4.3.1. Putting the mower onto another vehicle for transport

The driver and the carrier are responsible for mower's transport safety. Equipment and parts must be secured during transport.

To put the mower onto another vehicle in a safe way, please obey the following rules:

- seize the mower by any lifting devices only in the places indicated by the hook sign (**Fig. 5**),

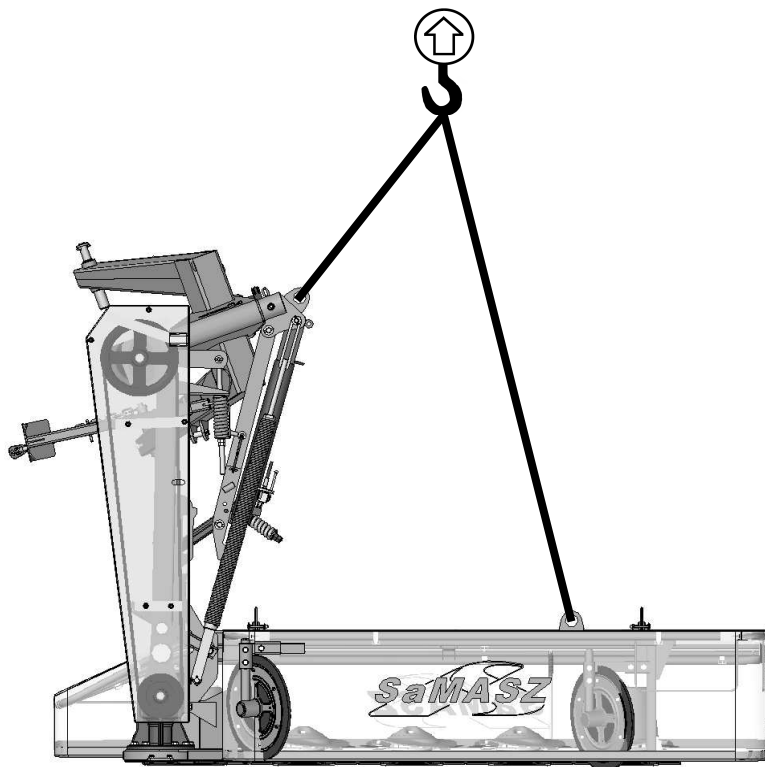

**Fig. 5.** Transport holders

- for mower lifting use only lifting devices with hoisting capacity bigger than mower's weight shown in data plate. It also concerns ropes and chains used for lifting,
- transport belts, belt suspensions, ropes cannot be damaged. Whenever damages to these parts are spotted replace these with new ones,
- when mounting slings, chains, handles etc. always pay attention to setting the machine's center of gravity properly,
- to catch machines, pick ropes of adequate length, so that the angle between them is no greater than  $120^\circ$ , and the angle between the strand and the vertical is no greater than  $60^\circ$ ,
- collapsible parts should be blocked in transport position,
- during putting the mower onto another vehicle it is forbidden for anybody to remain in transport area,
- on the vehicle's trailer the machine should be secured against moving.



#### **CAUTION:**

Securing manouvering area and transport of the mower is the responsibility of a person who does it.

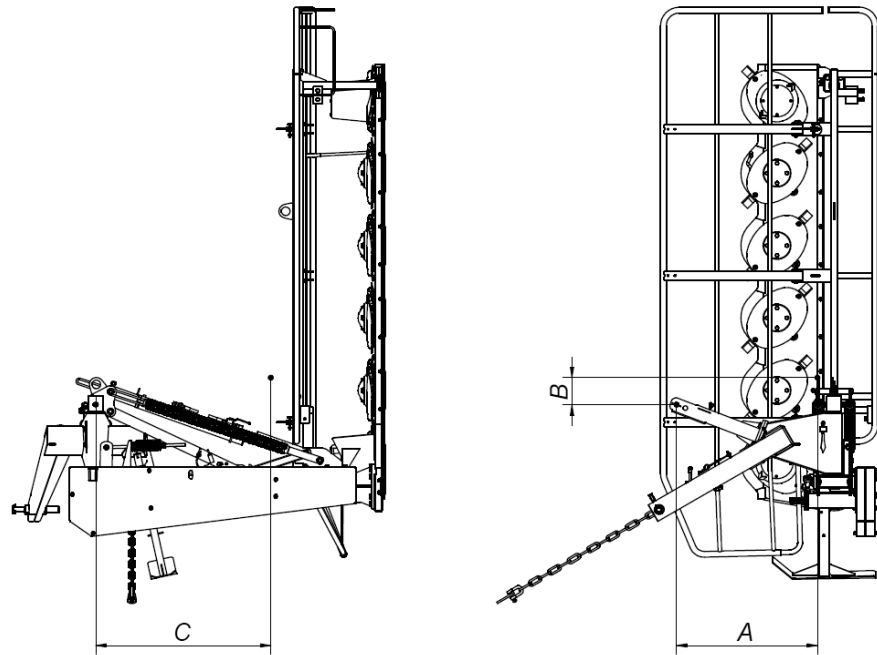

**Fig. 6.** Location of centre of gravity

**Tab. 4.** Location of centre of gravity

Dimension [mm]	Model				
	KDT 180	KDT 220	KDT 260	KDT 300	KDT 340
A	730	715	815	710	700
B	130	25	160	310	460
C	840	970	1010	1045	1080

Dimension [mm]	Model			
	KDT 220 S	KDT 220 W	KDT 260 S	KDT 260 W
A	835	850	825	840
B	105	140	200	220
C	1010	1060	1030	1080

#### 4.4. Working parts

- ❑ Before operating the mower check knife's and knife holder's condition.
- ❑ Worn or damaged knives or knife holders should be immediately replaced with new one.

#### 4.5. PTO shaft

- ❑ Before operating learn provisions found in bar manufacturer's manual placed on the bar.
- ❑ Use only PTO shafts recommended by mower's manufacturer with guards in good condition.
- ❑ In order to operate safely use only fully technically fit, undamaged PTO shafts. Damaged PTO shaft shall be repaired or replaced with new one.

## 4.6. Hydraulic assembly

- ❑ Caution! Hydraulic assembly is under pressure! Hydraulic oil under pressure may permeate through skin and cause serious injury, therefore skin and eyes should be protected in particular. In case of injuries caused by a liquid under pressure, call a doctor immediately.
- ❑ Hydraulic hoses can be connected to tractor's hydraulics, provided that both the tractor's and the mower's hydraulic assemblies are not under pressure. To remove the pressure from the hoses just simply restart the tractor's hydraulic valves several times, once the tractor is off.
- ❑ When dismounting the machine from the tractor, set the equipment aside, deflate the pressure from hydraulics and turn tractor's engine off.
- ❑ When controlling for hydraulic assembly's malfunction and looking for oil leaks, it is forbidden to touch any potential leaks until the entire assembly is under pressure.
- ❑ **Note! It is recommended to use hydraulic oil featuring oil purity class 9 - 10 in accordance with NAS 1638.**

### When using hydraulic hoses:

- ❑ Avoid stretching the hoses when operating.
- ❑ Do not allow hydraulic hoses to get deflected.
- ❑ Do not expose hydraulic hoses to contact with any sharp edges.
- ❑ If damaged or worn, replace the hoses with new ones.
- ❑ Useful life for hydraulic hoses is 5 years from their production date.

## 4.7. Residual risk

Despite the fact, that SaMASZ Sp. z o.o. Białystok company – the manufacturer of the mower takes the responsibility for the mower design and manufacturing, in order to eliminate hazard, certain risk when operating the mower is unavoidable.

Major source of risk follows performance of these operations:

- ❑ operation of mower by minors as well as not being familiarized with operator's manual,
- ❑ operation of mower by persons under influence of alcohol or other abusive substances,
- ❑ not keeping caution while transportation and shifting of mower during operation,
- ❑ transport of persons remaining on the machine,
- ❑ presence of persons and animals within the mower operation range,
- ❑ performing operations related to servicing and adjustment with engine on.

### 4.7.1. Danger of catching

This kind of risk occurs during changing the position of a mower, operation near rotating parts, working without safety guards. During operation, maintenance and reulations always wear protective gloves, shoes and clothes without loose parts, belts and so on. Always comply with safety decals placed on the mower.

### 4.7.2. Danger of injury

This kind of risk occurs during replacement of working parts with sharp edges. During any maintenance work always use safety gloves.

#### 4.7.3. Danger of liquid ejection out of hydraulic system

During connection of hydraulic hoses to hydraulic connectors make sure, that either tractor's or mower's hydraulic system is without pressure. During operation of hydraulic system always wear protective glasses and gloves. Check regularly hydraulic hoses.

**CAUTION:**

Residual risk always results from incorrect behaviour of mower's operator.

#### 4.7.4. Bans

Please bear in mind the following bans during mower's operation:

- ❑ never unblock the mower, make any regulations or repairs of the mower while it is in motion,
- ❑ never change the order of operation and maintenance activities described in operator's manual,
- ❑ never operate the mower when it is not in working order or has damaged safety guards,
- ❑ never get your hands and legs close to rotating parts of the mower,
- ❑ during repair and maintenance of the mower always comply with the descriptions included in operator's manual. Always do these activities when the tractor's drive is off,
- ❑ before you start any activities, focus your attention on them,
- ❑ never operate the mower under the influence of alcohol, drugs, or strong medicines,
- ❑ your clothes should not be too loose, or too tight. Too loose cloth parts may be pulled in by the rotating parts of the mower,
- ❑ the mower cannot be operated by children or by handicapped people.

When describing residual risk, the mower is treated as a machine, that up to the moment of its putting in motion it had been designed and manufactured according to technology level actual till the day of mower's manufacture.

**CAUTION:**

Residual risk occurs in case of not complying with described instructions and bans.

#### 4.5.5. Residual risk evaluation

When keeping such recommendations as:

- ❑ thorough familiarizing with operator's manual,
- ❑ no persons remaining on the machine when operating and during drives,
- ❑ no persons remaining within the mower operation range,
- ❑ adjustment, maintenance and lubrication of the machine with engine off,
- ❑ performing repairs of the machine only by skilled persons,
- ❑ operation of the machine by persons, which are familiarized with operator's manual,
- ❑ in the event of the machine protection against children and unauthorized personnel residual risk when operating the mower may be limited to necessary minimum.



When the risk of exposing to noise cannot be avoided or eliminated by any group protective means or organization of work, employer (farmer) must:









- 1) provide the operator with individual means of noise protection, if the noise level in work place exceeds 80 dB.
- 2) provide the operator with individual means of noise protection and supervise the correctness of its usage, if the noise level in work place reaches or exceeds 85 dB.

**4.8. Warning decals and their meaning**







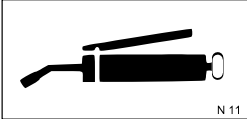
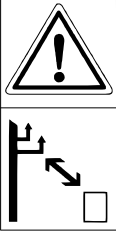
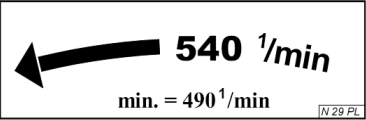
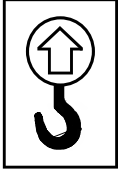

**CAUTION:**

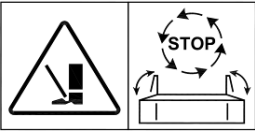
- a) all warning decals should be clean and legible,
- b) lost or damaged decals must be replaced,
- c) please order new decals from your dealer or supplier.

 <p>N-1 Be extremely careful when PTO shaft is rotating</p>	 <p>N-2 CAUTION: cutting knives. Approach during operation is forbidden</p>	 <p>N-3 Read the operator's manual before putting the mower into operation</p>
 <p>N-4 While making repairs the machine must be stopped</p>	 <p>N-5 CAUTION: belt transmission, be extremely careful</p>	 <p>N-6 CAUTION: pulling-in parts</p>
 <p>N-7 Operating is forbidden when any person is within the danger area of 50 m</p>	 <p>N-9 CAUTION: rotor</p>	 <p>N-11</p>
 <p>N-23 Watch out: power lines</p>	 <p>N-29</p>	 <p>N-40 Signs indicating transport holders</p>



 <p>N-48 Stay away from mower's inclination area</p>	 <p>N-49 Never stand near tractor's 3-point linkage while steering tractor's lift</p>	 <p>N-50 Do not stay in the swinging area of mower's parts</p>
 <p>N-52 Wear protective gloves</p>	<p><b>16 MPa</b></p> <p>N-55</p>	 <p>N-117 Under pressure. Consult technical manual for service procedures</p>
 <p>N-167 Do not go onto safety brackets and guards</p>	 <p>N-168 Do not touch the machine before the rotating parts have not come to a complete standstill</p>	

OPTIMUM INCLINATION TOWARDS THE GROUND IS 3° - 4° TO THE MOWING DIRECTION.

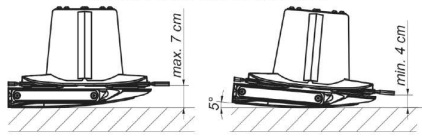

IT IS ALLOWED TO WORK IN HORIZONTAL POSITION. DIFFERENT INCLINATION MAY DAMAGE THE MOWER.

N 30 EN

N-30 Cutterbar "Perfect Cut"

**CLEAN THE MOWER EACH DAY AFTER WORKING**

Especially between discs and the cutterbar, because grass with mud may damage bearings in the disc module.

N 31 EN

N-31

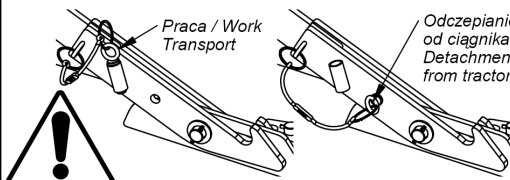

N-32

N-32

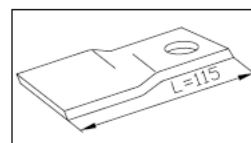

N-34

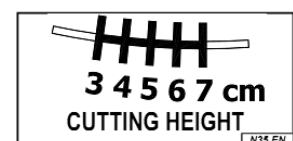

N-35 Cutterbar "Perfect Cut"

- Optimum work parameters**
1. Inclination towards the front 0+5 degrees which stands for 4,5+7 cm of mowing height.
  2. Operation speed  $\geq 10$  km/h.
  3. PTO rpm = 950+1000 rpm. PTO rpm > 1000 may cause stripes of uncut grass between the discs.
  4. Tractor's rpm (max. moment – economical fuel consumption 1600+1800 rpm).
- High and inclined grass**
5. Highten the cutterbar's inclination to -H = about 4,5cm.
  6. Operation without cutterbar's inclination may cause winding of grass on the forming drums.
  7. Speed up to  $V \geq 12$  km/h. (the faster – the better).
  8. Do not take turns in the mowed grass.
- N53EN - 1000 obr.

N-53

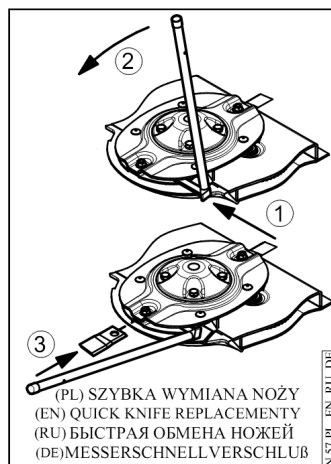

N-57

**WORKING WITHOUT GUARDS IS FORBIDDEN**  
DANGER OF THE STONES, ETC. BEING THROWN OUT

P2 EN

P-2

**DANGER**  
OPERATING WHEN ANY PERSON REMAINS IN THE DANGER AREA OF 50 m

P3 EN

P-3

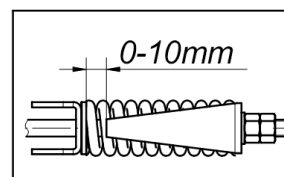

P-6

**540 1/min**  
min. = 490 1/min

**16 MPa**

**3 4 5 6 7 cm**  
CUTTING HEIGHT

**0-10mm**

**OPTIMUM INCLINATION TOWARDS THE GROUND IS 3°-4° TO THE MOWING DIRECTION.**  
IT IS ALLOWED TO WORK IN HORIZONTAL POSITION. DIFFERENT INCLINATION MAY DAMAGE THE MOWER.

**WORKING WITHOUT GUARDS IS FORBIDDEN**  
DANGER OF THE STONES, ETC. BEING THROWN OUT

**DANGER**  
OPERATING WHEN ANY PERSON REMAINS IN THE DANGER AREA OF 50 m

**Optimum work parameters**

1. Inclination towards the front 0+5 degrees which stands for 4,5+7 cm of mowing height.
2. Operation speed  $\geq 10$  km/h.
3. PTO rpm = 950+1000 rpm. PTO rpm > 1000 may cause stripes of uncut grass between the discs.
4. Tractor's rpm (max. moment – economical fuel consumption 1600+1800 rpm).

**High and inclined grass**

5. Highten the cutterbar's inclination to -H = about 4,5cm.
6. Operation without cutterbar's inclination may cause winding of grass on the forming drums.
7. Speed up to  $V \geq 12$  km/h. (the faster – the better).
8. Do not take turns in the mowed grass.

N53EN - 1000 obr.

**Fig. 7a.** Warning decals placed on the mower without conditioner

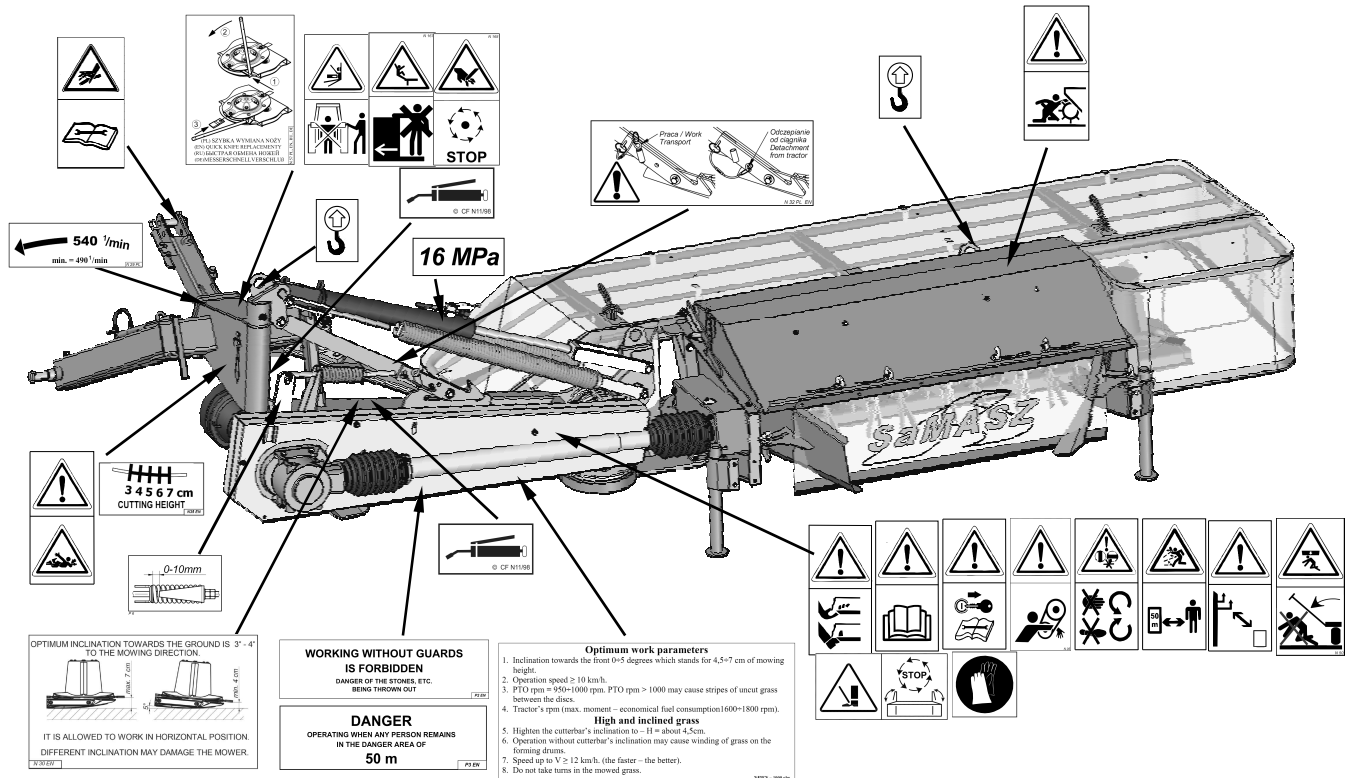

**Fig. 7b.** Warning decals placed on the mower with tine/roller conditioner



**CAUTION:**

Any spare part used for repair of the mower should have all warning decals provided by the manufacturer.

**5. OPERATION**

**5.1. Attaching the mower to the tractor**

The mower is connected to the tractor's 3-point-linkage (**Fig. 8**). After the mower has been attached, adjust (on the flat ground) the mower's position by means of top **S** and lower **W** links (**Fig. 8**). The cutterbar should lean towards the driving direction. Lower links **W** should be connected to 3-point linkage frame pins **A**. Support chain **L** holds up mower's linkage frame.

Connect hydraulic hose to tractor's hydraulic connector.

After the mower has been attached to tractor, check the balance and steerability of tractor-mower set. To do it, weigh the set and after that drive on the weigher with only the front axis of the tractor (the mower must be in transport position – lifted upwards). If the pressure on the front axis is at least 20 % of the whole set's pressure, it means the set is stable. If not, the front axis should be balanced.

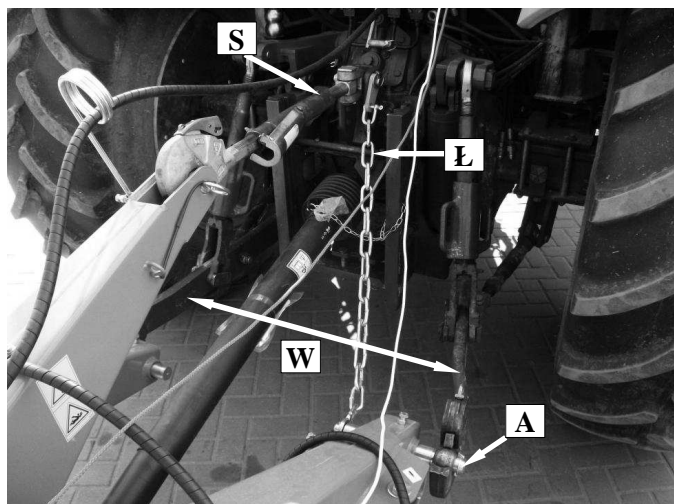

**Fig. 8.** Connecting the mower to the tractor

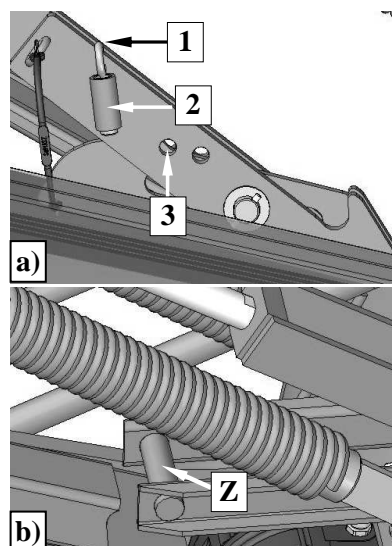

**Fig. 9.** a) 1 - pin, 2 - bush, 3 - hole in the bar b) Z - lock



**CAUTION:**

Before disconnecting the mower put the pin 1 (**Fig. 9a**) into the hole 3 in the bar (**Fig. 9a**) to secure the linkage against falling. When the mower is connected the pin should be in the bush 2 (**Fig. 9a**) on the middle bar.

**5.2. Preparing the mower for transport**

To prepare the mower for transport and to meet safety precautions, please do the following:

- ❑ lift the mower with tractor hydraulic lift until the lower lift pins of the mower 3-point linkage frame raise about 0,5 m above the ground (**Fig. 11**),
- ❑ lift support leg up and secure it with split cotter,
- ❑ remove the pin 1 and put it into the bush 2 (**Fig. 9a**),
- ❑ lift the cutterbar by hydraulic cylinder vertically until the pawl Z locks in (**Fig. 9b**),
- ❑ secure the cutterbar against falling by the shut-off valve (**Fig. 10b**) placed on the mower's hydraulic cylinder.



**CAUTION:**

During transport the shut-off valve of mower hydraulic lift should always be closed – the valve lever in Z position (**Fig. 10**). It protects the mower against incidental falling in case of hydraulic failure.

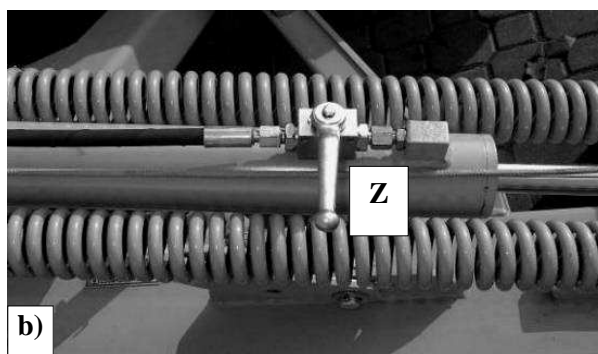
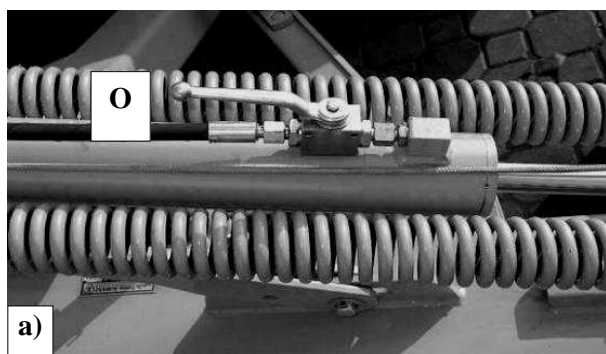

**Fig. 10.** Shut-off valve position: a) open(work), b) closed(transport)



**Fig. 11.** Rear disc mower in its transport position

### 5.3. Preparing the mower for transport on public roads

To meet safety precautions concerning transport on the public roads in Poland the mower should be equipped with the following devices:

- portable warning-light plates, to be mounted on both sides of mower top guard in their holders,



**CAUTION:**

The warning devices can be ordered from the mower manufacturer.



**CAUTION:**

Pay particular attention to power lines if the transport height exceeds 4 m (for mowers of type KDT 340).

- warning triangle which can be put into holder on top mower guard.

### 5.4. Mounting PTO shaft

PTO shaft's end with overrunning clutch should be mounted on mower's side.

When connecting PTO shaft between tractor and mower make sure, that external guard tube of the shaft is on the tractor's side. The PTO shaft plastic guards have to be secured by fastening their small chains to immovable parts of tractor and mower.



**CAUTION:**

If need be, shorten the PTO shaft according to its operator's manual given by the shaft's manufacturer (**Fig. 12**).

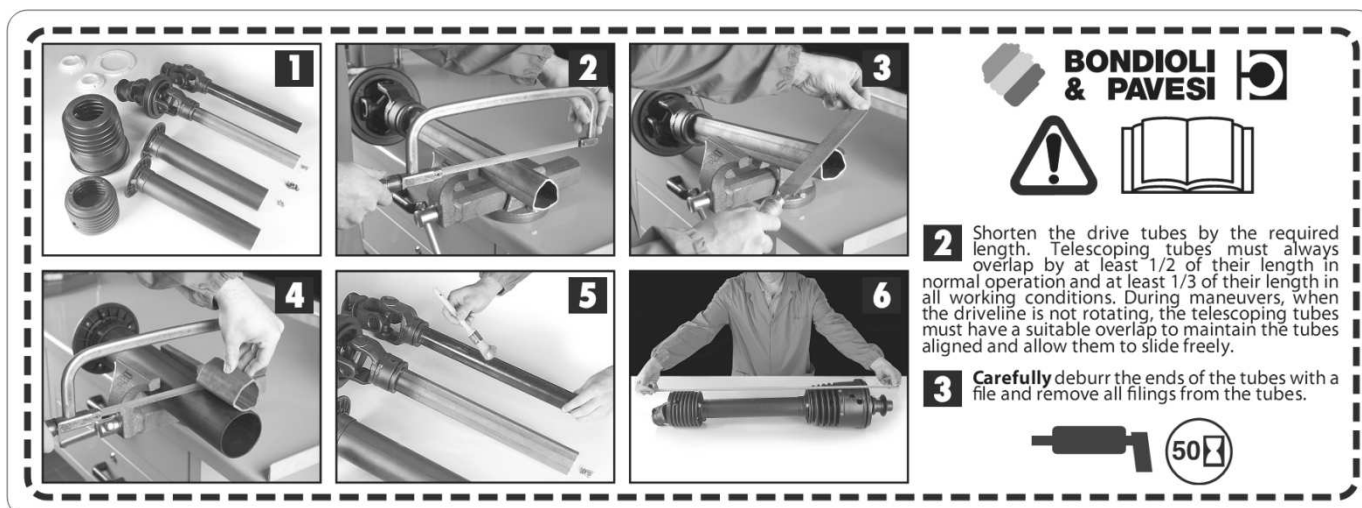

Fig. 12 Instruction of PTO shaft shortening



**CAUTION:**

Use the machines with PTO shafts designed to drive them. Before the work begins, check the safety guards (in tractor, mower and PTO shaft), if they are placed correctly and are not damaged. Damaged or lost parts must be replaced with genuine ones. Make sure the PTO shaft is properly mounted. It is forbidden to approach the rotating parts, because it may lead to serious injuries or even death. All service and repair operations must be done only after the tractor engine has been stopped, all rotating parts have come to the complete standstill and the cutterbar is on the ground. Before the operation begins, read operator's manuals of both the machine and PTO shaft.



**CAUTION:**

PTO shaft's end with overrunning clutch should be mounted on mower's side.

**5.5. Switching from transport to working position**



**CAUTION:**

Switching the mower from operating position to transport position and vice versa could only take place on even and stable ground. Prior to approaching works make sure whether there are no unauthorized persons exposed to getting crushed.

- open the shut-off valve on the hydraulic cylinder (Fig. 10a),
- lower the mower until the cutterbar is at least 40 cm above the ground,
- make sure there is nobody around in the place where you are going to lower the mower,
- tighten the cord until the lock **Z** is released (Fig. 9b) and by means of hydraulic cylinder put the mower into horizontal position,
- with tractor's lever lower the cutterbar to reach the horizontal position in a possibly slow way,
- lower the mower until the support chain tightens. If the 3-point linkage frame is more than 40 cm above the ground, adjust the chain.

- By means of link **S** (**Fig. 8**) adjust the cutting height. Extending the link **S** increases the cutting height and shortening the link reduces it.
- The proper distance between the end of cutterbar and tractor's tyre **Y** should be about 0 to 10 cm for KDT 180, KDT 220, KDT 260. For KDT 300 **Y** should be from 30 to 40 cm. For KDT 340 from 50 to 60 cm.

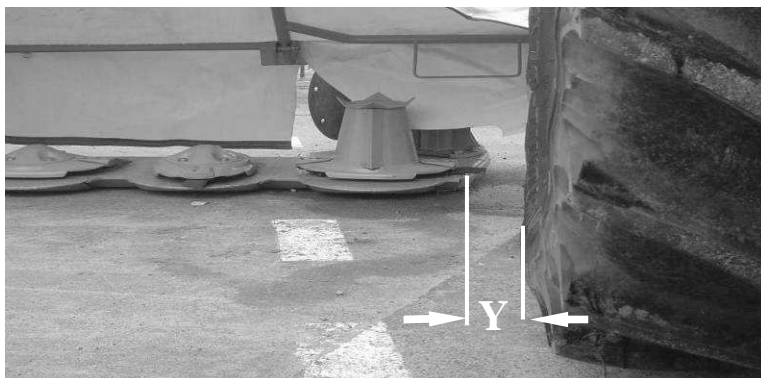

For KDT 180; KDT 220;  
KDT 260

**Y** = from 0 to 10 cm

For KDT 300

**Y** = from 30 to 40 cm

For KDT 340

**Y** = from 50 to 60 cm

**Fig. 13.** The proper distance between the cutterbar and tyre

## 5.6. Preparing the mower for work

### CAUTION:



During storing of the machines in company SaMASZ the cylinders are protected by special grease in order to secure them against weather which may cause their premature wear. Before starting the operation excess grease should be removed from the cylinders.

Put the mower into motion when the cutterbar is on the ground so that oil can fill the whole cutterbar. When the mower is in working position, please do the following:

- lower the cutterbar to the ground,
  - connect PTO shaft between tractor and mower,
  - by means of upper regulating bar of the mower, adjust the cutterbar's height and inclination towards the ground. Proper inclination of the cutterbar is between 0° and 5°. It is regulated by extending or shortening the bar,
  - slowly engage PTO clutch and wait until the cutting unit reaches its rated speed. DO NOT exceed 480 ÷ 540 rpm,
  - engage tractor gear and drive slowly into the grass-field. Flat meadows can be mowed with any speed. If the meadow is uneven reduce speed.



### CAUTION:

DO NOT pull the cutterbar in other way (towards the tractor), because it will lead to cutterbar's premature wear or even its damage.

## 5.7. Operation (mowing)

### Dear operator,

If the disc mower is your first experience (you have mowed with 2-drum mower) you need a piece of essential information:

1. The main advantage of disc mowers is their small power demand – 20% less tractor power, small moment of inertia and possibility to manufacture mowers with large working width.
2. There is however a certain disadvantage - creased stubble, especially when it comes to lying grass. Straight grass may be mowed with horizontal adjustment of the mower and then the stubble will be even but it will not look as attractive as with 2-drum or 4-drum mower, because the knives work horizontally to the ground and inclined grass bends because of wind blasts. After the grass is mowed it gets up, which makes an impression of inaccurate mowing. Every mower may leave stripes of uncut grass when it comes to the knives which cut the grass towards the grass direction. It is a normal phenomenon. Practically, it is not possible to achieve such attractive stubble as in 2-drum mowers, because the knives work horizontally or at an angle of up to 8° to the ground, and when it comes to 2-drum and 4-drum mowers slantwise through the ground (even 23°).

Despite these 'disadvantages', disc mowers are 'winning farmers' trust' and modern technologies give the opportunity to manufacture very durable mowers (even up to 1000%).

### 5.7.1. Essential information concerning mowing

#### Optimum work parameters

1. Inclination towards the front 0÷5 degrees which stands for 4.5÷7 cm of mowing height.
2. Operation speed  $\geq 10$  km/h.
3. PTO rpm = 480÷540 rpm. PTO rpm > 540 may cause stripes of uncut grass between the disc.
4. Tractor's rpm (max. moment – economical fuel consumption 1600÷1800 rpm).

#### High and inclined grass.

1. Heighten the cutterbar's inclination to – H = about 4.5 cm.
  2. Operation without cutterbar's inclination may cause winding of grass on the forming drums.
  3. Speed up to  $V \geq 12$  km/h (the faster – the better)
  4. Do not take turns in the mowed grass.
- Optimum inclination of the cutterbar towards the ground is between 0° to 5°. If the inclination exceeds 5°, there might be a slight unevenness of the mowed grass. It impairs slightly the quality of mowing and has an influence on mower's operation. When the cutterbar is pulled in the other way, it significantly impairs the quality of mowing and in some cases the mower stops mowing. Besides, it may lead to premature wear or even damage of the slides and cutterbar.
  - When the high grass prevails, the first and the second cut should be mowed at the height level - 6 - 7 cm, but when the grass grows low – at the height level - 5 cm. The last cut should be mowed a little bit higher – 7 - 8 cm above the ground.
  - Too high PTO rpm whirl the air, which may cause the inclination of the grass in front of the discs. It impairs the quality of mowing.
  - Too low PTO rpm impair the quality of mowing and in some cases the mower stops mowing.(too low linear velocity of the knife).
  - In contrast with 2-drum mowers straight mounting of the mower and full speed is not always possible. Adjust experimentally the inclination of the mower, PTO rpm, speed and correctness of knife-mounting.
  - In case of mowing soft meadows the pressure of the cutterbar on the ground should be reduced by adjusting support springs.



### 5.7.2. Design and and operation of safety breakaway device

In the event of hitting an immovable obstacle one of the safety device flat bars slides out and disconnects the safety device. After that the mower folds back about 34 degrees (**Fig. 15**). The operator has time to shut off the tractor and protect the mower. Safety device spring is adjustable (**Fig. 14**), therefore changing the force needed to make safety device work.

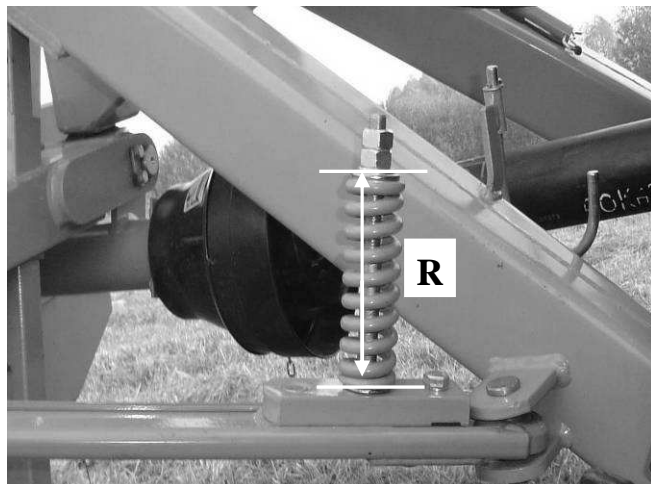

**Fig. 14.** Safety device

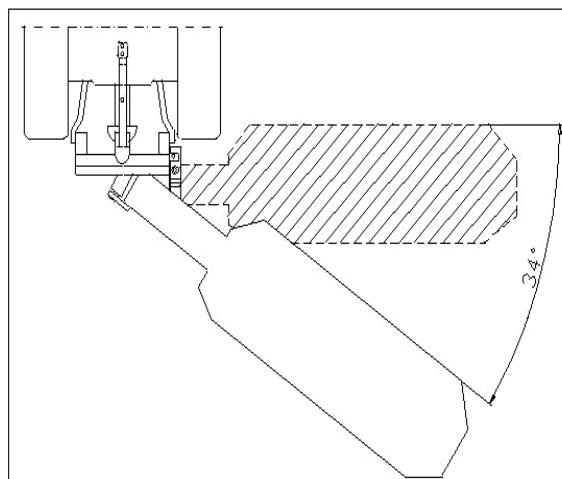

**Fig. 15.** The mower breaks back when the safety device operates

Recommended length of safety device spring **R** (**Fig. 14**) should be 143 mm. If the safety device breaks away too easily, tighten up the spring approximately 1-2 mm. DO NOT tighten up too much, because you may prevent the safety device from working and damage the mower.

### 5.7.3. Mower clogging

When operating the mower pay attention to variable conditions on field, which may influence the mower clogging, such as: terrain unevenness, height and density of grass as well as other objects in the grass. In order to avoid clogging, mowing speed should be adjusted to the mentioned conditions. In order to remove the machine clogging, lower the cutterbar onto the ground, disconnect the drive, take ignition key off and pay particular attention. When eliminating the mower's clogging, use also safety means for operator, so protective gloves and tight wear.

### 5.7.4. Taking turns over swaths

Lift the mower with hydraulic cylinder and take the turn. The mower does not need to be additionally lifted by tractor's 3-point linkage.

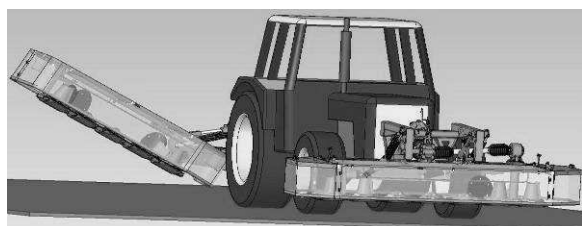

**Fig. 16a.** KDF i KDT mower set prepared to take turns

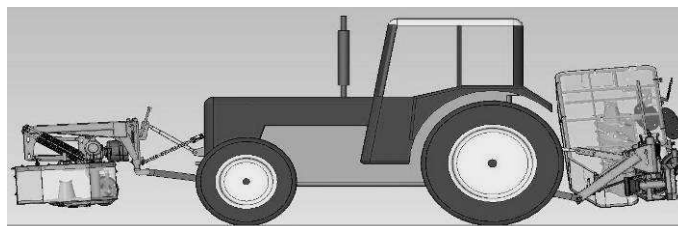

**Fig. 16b.** KDF i KDT mower set prepared to take turns

## 5.8. Dismounting mower from tractor



### CAUTION:

When dismounting, make sure there is no person in between the mower and the tractor.

To dismount the mower from the tractor:

- turn cutterbar's drive off,
- place the mower on even, paved ground, lower and protect support legs, check, if the mower is properly protected against falling,
- turn the tractor's engine off and take ignition key off,
- dismount tractor's rpm and place it on a PTO shaft holder, that is standard-delivered with the mower,
- disconnect hydraulic hose,
- detach tractor's upper link and lower strands from mower's linkage.

## 6. MOUNTING AND ADJUSTMENTS

### 6.1. Mounting and timing of the knives

The knives should be mounted as shown in **Fig. 17** and **18**, according to the rule, that the cutting edges should be directed towards ground, so that a knife will lift the grass after cutting. The manufacturer recommended knives are measured 105x49x4 and conform to standard PN-EN 795:2002.

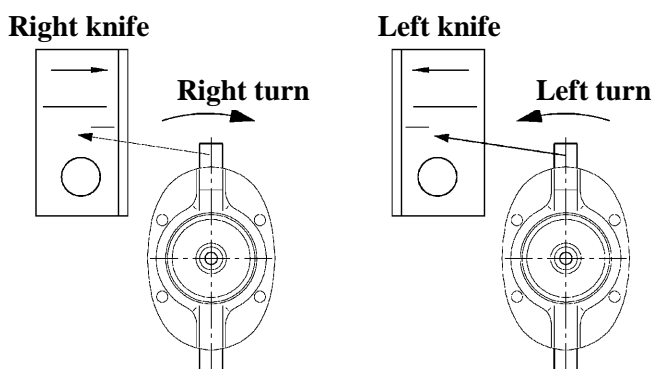

**Fig. 17.** Mounting of the knives on the mowing discs



### CAUTION:

Use only the knives recommended by the manufacturer.



### CAUTION:

Condition of knives and holders should be checked each time before commencing any operation. Damaged or worn elements pose danger of throwing and are as well health and life threatening.

## 6.2. Replacing the knives

Worn and/or damaged knives should be immediately replaced.

Replace knives, if necessary, only in sets. Make sure all knives in a set are of the same length and weight. The knife holders (**Fig. 28**) must not be damaged or deformed. If the knife holder pin is worn too much, please replace it immediately.



### CAUTION:

During work, please pay particular attention to mower's shaking. If it happens, it means that the disc (discs) works only with one knife. In that case long-lasting mowing will cause serious damage of the cutterbar.



### CAUTION:

When replacing knives the engine must be stopped and the cutterbar must lie on the ground. PTO shaft must be disconnected. Discs should be perpendicular to cutterbar (max. rotation  $\pm 20^\circ$ ).

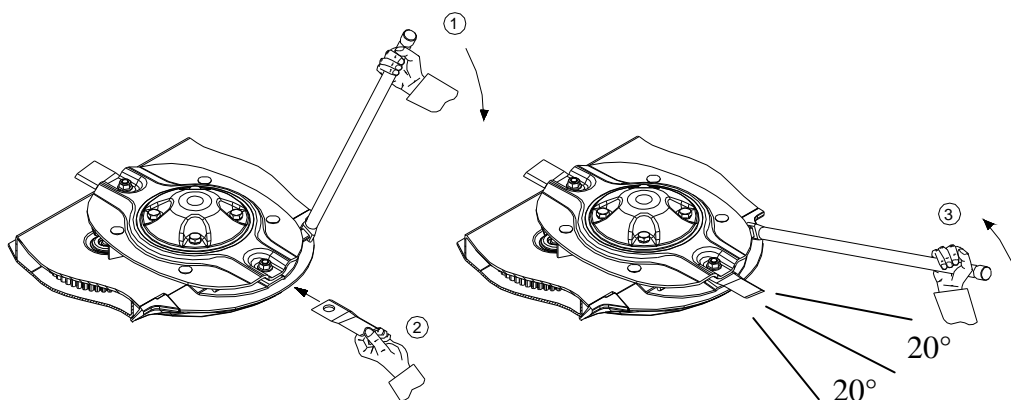

**Fig. 18.** Quick replacing of the knives with mounting lever

## 6.3. Adjusting the cutterbar

Swath width is adjusted with swath guides mounted on the 3-point linkage frame of the cutterbar (**Fig. 19**).

In order to adjust the guide, the following should be performed (for: KDT 180, KDT 220, KDT 260, KDT 300, KDT 340):

- loosen locknuts (2) and screws (3),
- shift the guide arm (6),
- tighten screws (3) and locknuts (2),
  
- loosen locknuts (4) and screws (5),
- then adjust height and shield angle (7),
- tighten screws (5) and locknuts (4).

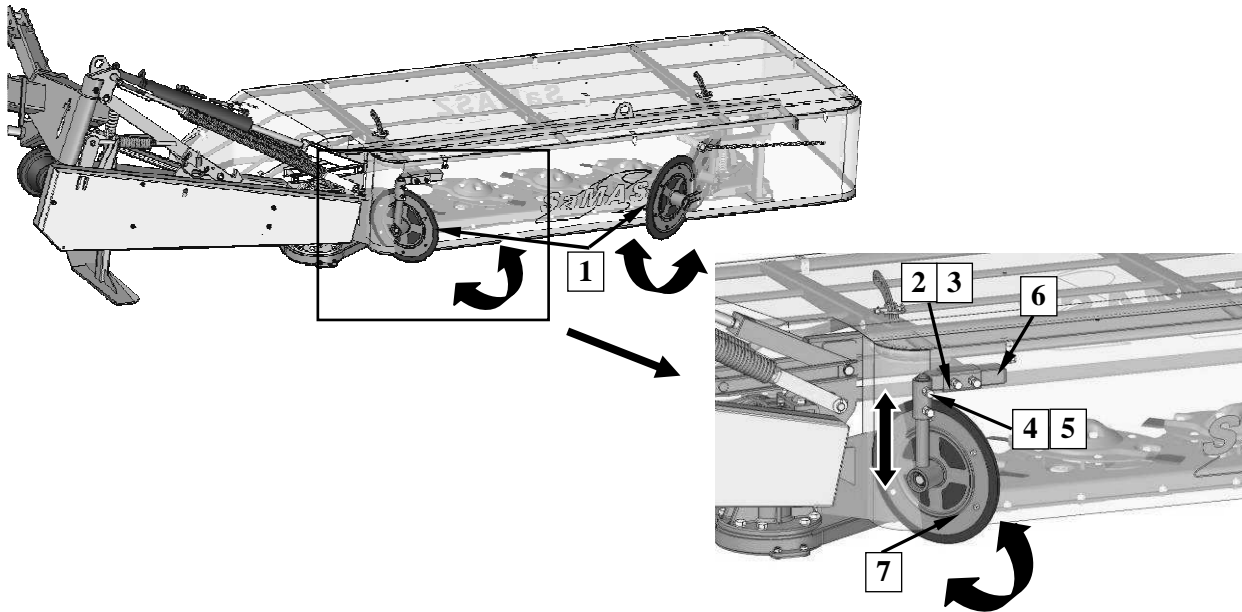

**Fig. 19.** Adjustment of swath guides: 1 - swath guide, 2 - locknuts, 3- arm adjustment screws, 4 - locknuts, 5- shield adjustment screws, 6- guide arm, 7- shield

In order to set swath width, adjustment of swath guides (1) should be performed (**Fig. 20**) (for: KDT 220 S, KDT 260 S):

- ❑ loosen eye screw (2) of the swath guide,
- ❑ set the swath guide (1) as needed,
- ❑ tighten screw (2),
- ❑ even spreading of swath might be adjusted with wheels (3) the same as it is preformed with guides.

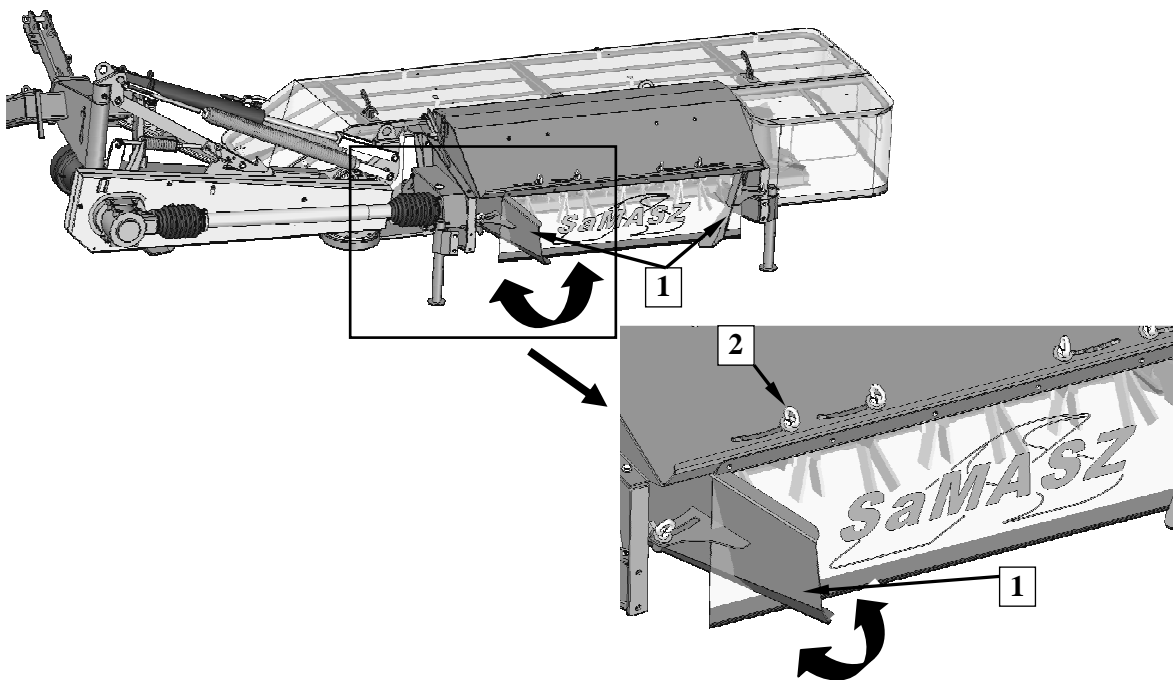

**Fig. 20.** Adjustment of swath guides: 1- swath guide, 2 - adjustment screw, 3 - swath wheel

In order to set swath width, adjustment of swath guides (1) should be performed (**Fig. 21**) (for: KDT 220 W, KDT 260 W):

- ❑ loosen eye screw (2) of the swath guide,
- ❑ set the swath guide (1) as needed,
- ❑ tighten screw (2).

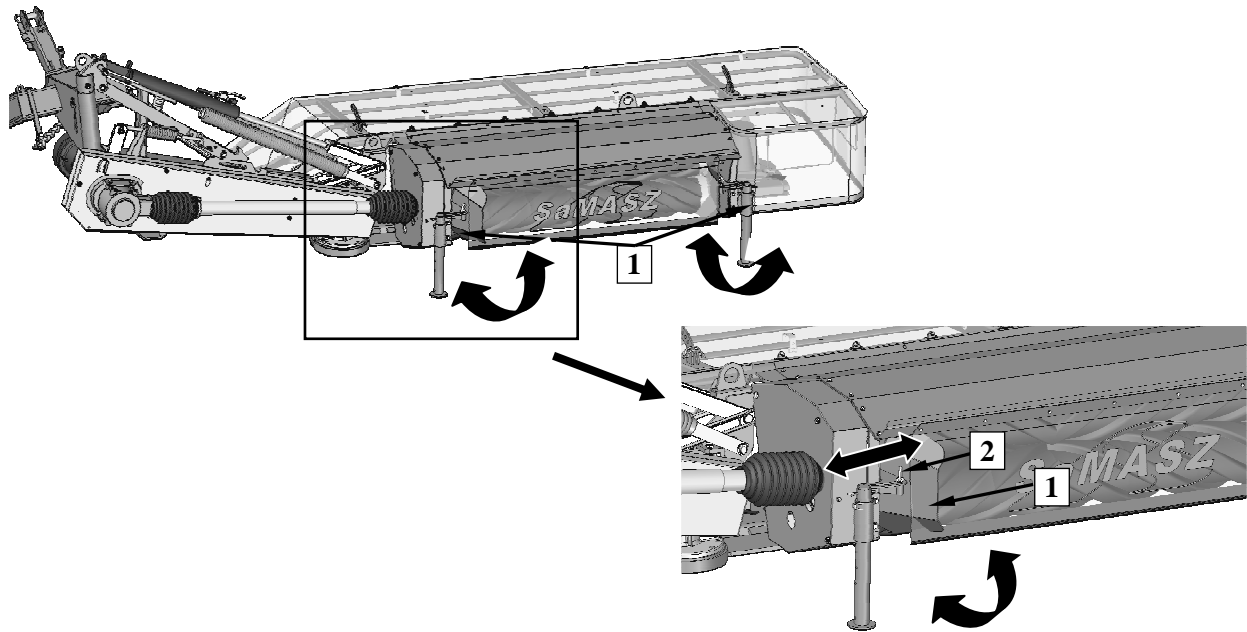

**Fig. 21.** Adjustment of swath guides: 1- swath guide, 2 - adjustment screw



**CAUTION:**

Before you change the knife check disc turns (**Fig. 22**).



**CAUTION:**

Different mounting of the knives will block the mower. When mounting pay particular attention to loose rotation of the knife on the knife holder pin.



**CAUTION:**

Because of high discs rpm, knife holders should be changed in sets of the same weight – on every holder there is its weight written. Improperly changed knife holders will damage disc bearings.

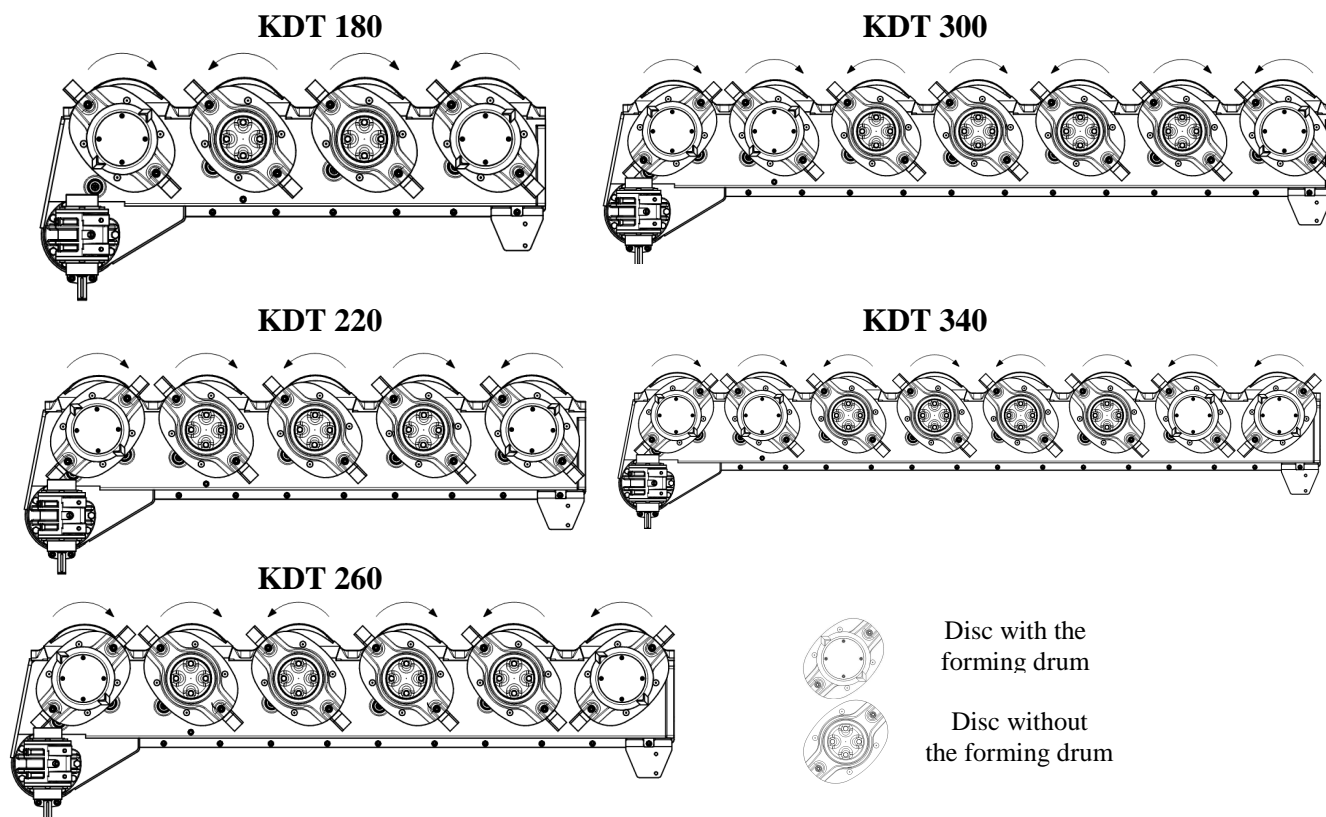

Fig. 22. Swath widths of SaMASZ disc mowers. By combining discs and forming drums, different swath widths can be reached

#### 6.4. Adjusting the cutting height

By means of upper link S (Fig. 8) adjust the cutting height. Extending the link S increases the cutting height and shortening the link reduces it. Cutting height is shown by the scale placed on the 3-point linkage frame (Fig. 23), recommended height is 4.5÷7 cm.



Fig. 23. Cutting height scale

#### 6.5. 3-point linkage support chain

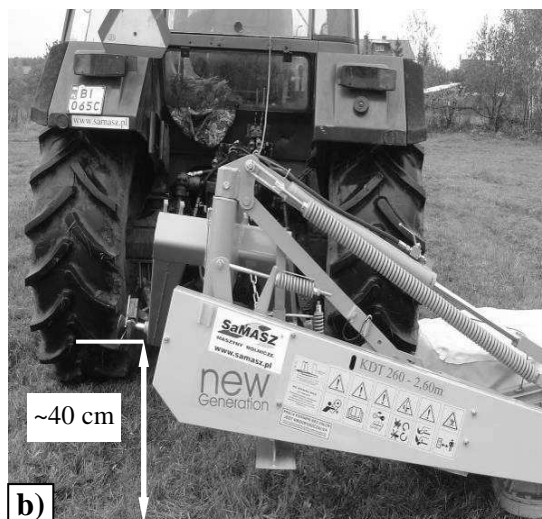
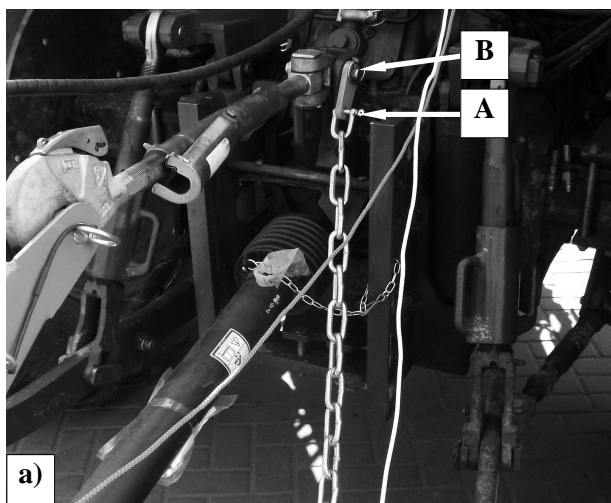

Fig. 24. Support chain

Support chain is used to ensure 3-point linkage frame of the mower is always at the same height, to set the mowing unit parallel to the ground and to relieve the hydraulic lift of the tractor.

When connecting mower to the tractor, the hanger plate **A** of support chain should be disconnected from chain and put on the pin **B** of upper link (**Fig. 24a**). Then the mower has to be lifted with hydraulic lift about 40 cm high (**Fig. 24b**). The support chain is then connected to the hanger plate **A**, so that is tensioned when the mower is in its working position. If the 3-point linkage frame is more than 40 cm above the ground, adjust the chain.

## 6.6. Adjusting the space between tine conditioner's mask and its shaft

(Models: **KDT 220 S** and **KDT 260 S**)

Depending on size and thickness of the mowing grass, there may be a necessity to adjust the mask of the conditioner. The higher and thicker grass, the bigger the space between conditioner's mask and its shaft should be. Proper adjustment should be based on the experience, in order not to block the conditioner and not to activate the friction clutch of PTO shaft. The way how the mask is regulated is shown in **Fig. 25**.

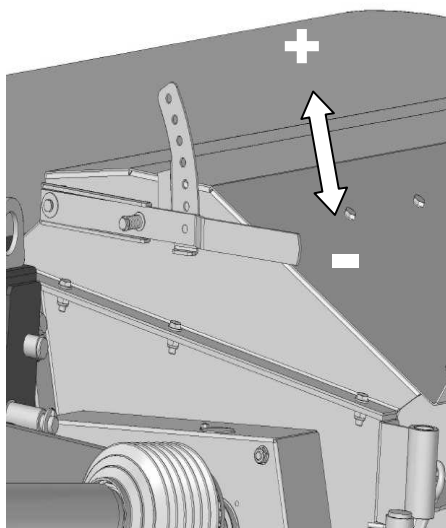

**Fig. 25.** Adjusting tine conditioner's mask

## 6.7. Replacing the conditioner's tines

(Models: **KDT 220 S** and **KDT 260 S**)

Worn tines must be immediately replaced with new ones. Each time, before the work begins, check the conditioner's tines along with the bolts on which the tines are mounted and tines' holders.

**Bear in mind, that flails should be replaced in pairs (opposite) featuring the same weight in order to keep shaft well balanced.** Not keeping the shaft well balanced may lead to premature wearing of bearings as well as the shaft itself.

Replacement of flails **3** consists in unscrewing of nuts **2**, removing bolts **4** and mounting brand new flails **3** (**Fig. 25**).



### **ATTENTION:**

In order to tighten screw connection use special purpose bolt M16×60 oc. kl. 10.9 and self-protected nut M16 oc. kl. 8; **torque down until tight.**

1. Scarfier shaft
2. Self-locking nut M16 oc. kl. 8
3. Flail
4. Bolt M16x60 kl. 10.9

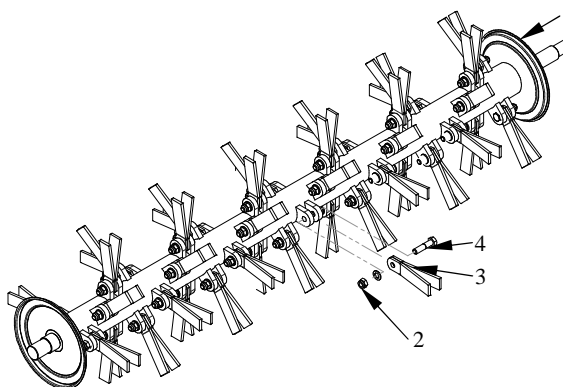
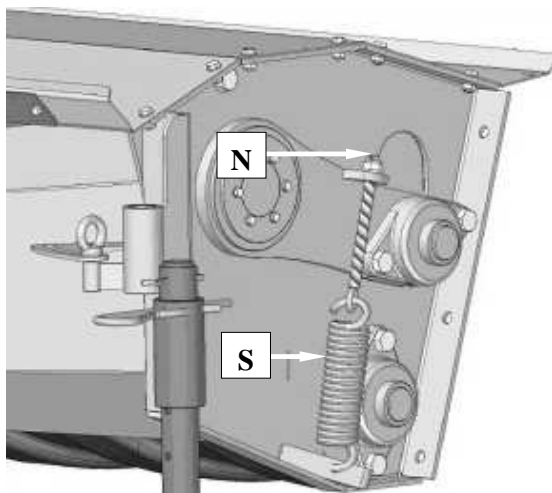

**Fig. 26.** Parts of tine conditioner

## 6.8. Adjusting force of the pressure of roller conditioner

(Models: **KDT 220 W** and **KDT 260 W**)

If need be, the force of the roller conditioner's pressure can be regulated by changing the tension of springs **S** (**Fig. 27**) by means of the nut **N**. Adjustment should be done on both sides of the conditioner



**Fig. 27.** Adjusting the force of the pressure of roller conditioner

## 6.9. Maintenance and service

### 6.9.1. Checking the knives and knife holders

All knives should have the same lengths and weights. Always check mower before starting work for damaged, missing and/or worn knives. Replace them, if necessary, only in sets. Make sure all knives in a set are of the same length and weight.

If the knife holder pin is worn too much and/or the knife holder is worn or deformed, please replace it immediately (**Fig. 28**).



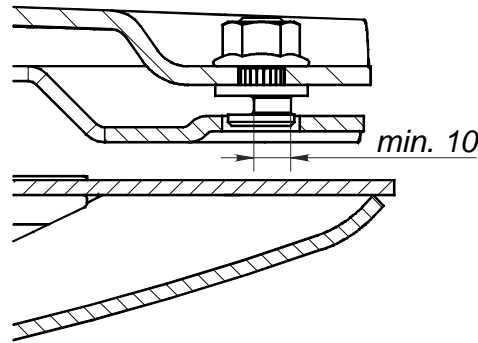

Fig. 28. Acceptable wear of the disc blade holder



**CAUTION:**

If the knife is missing or disc cover plate is damaged the vibrations may occur, which leads to cutterbar's damage. In that case warranty claim will be revoked.

If the disc or disc cover plate is damaged, the whole set must be immediately replaced (2 knives i 2 cover plates) with new genuine ones.

**6.9.2. Checking the V-belts tension**

Check the V-belt tension. V-belts are tensioned with spring tensioner (**Fig. 29**) equipped with checking plate. Distance **S** between plate tip and holder should be 10 mm. If the gap is wider the V-belts will be looser. Tensioning is done by nuts **N**. When any of the belts are damaged, the complete set must be replaced.

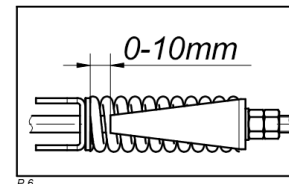
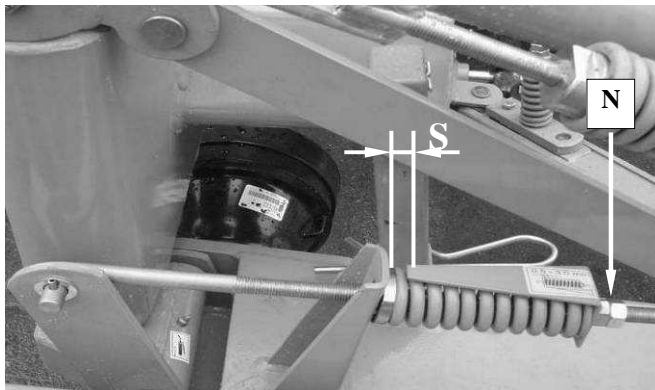
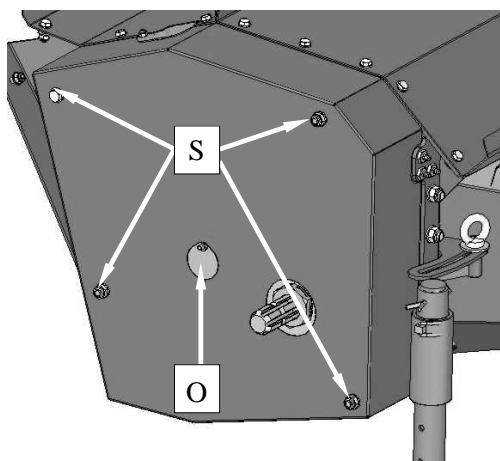
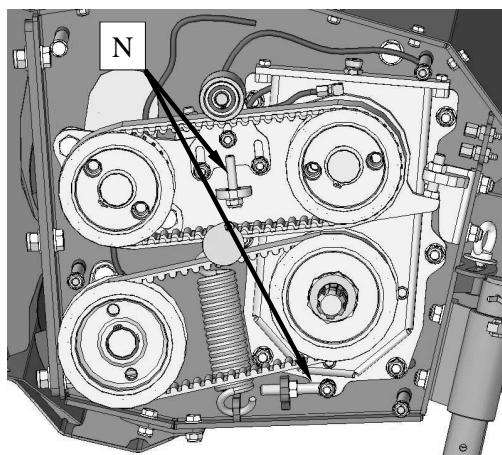

Fig. 28. Spring V-belts tensioner

**6.9.3. Checking the tension of tine and roller conditioners' driving chain**

Drive from PTO shaft is transmitted by means of driving chain on the conditioner. The tensioner provides the constant tension of the chain and is regulated by the nut **N** (**Fig. 30b**)

Tighten the chain by means of a nut **N**. The tension of the chain can be checked through the window **O** (**Fig. 30a**). To check the tension thoroughly, please remove the safety guard (**Fig. 30a**) after unscrewing four bolts **S**. A deflection of the properly tensioned chain under finger pressure should be about 5 mm.

**Fig. 30a.** Driving chain safety guard**Fig. 30b.** Roller gear cogbelt tension adjustment

#### 6.9.4. Daily maintenance

Everyday after work please carry out the following maintenance:

- ❑ clean the mower each day after working, especially between discs and the cutterbar, because grass with mud may damage bearings in the disc module,
- ❑ remove grass and mud,
- ❑ check all visible units and parts and their connections; tighten all loose bolts and nuts and replace all damaged and/or worn parts with new genuine ones,
- ❑ check the cutterbar,
- ❑ grease PTO shaft tubes with STP grease,
- ❑ if necessary, lubricate the parts and units according to lubrication instructions (chapter 7).

Parts, which may cause risk to operator's health and safety are as follows: damaged disks, tarpaulin covers, worn or damaged hydraulic hoses, PTO shaft guides, worn knives and knife holder pins.

#### 6.9.5. After-season maintenance and storing of machine

It is recommended for the operator to wear protective gloves when performing maintenance works.

Upon completion of operation the following shall be performed:

- ❑ lower the mower's cutterbar onto the ground,
- ❑ take the PTO shaft extension out of the tractor rpm or dismount the complete PTO shaft and install it into corresponding holder at the 3-point linkage frame,
- ❑ detach hydraulic and electrical hoses out of the tractor and hang them onto corresponding holders on the 3-point linkage frame,
- ❑ detach the mower from the tractor (reverse procedure as in case of attaching the mower to the tractor item 5.1), and then drive the tractor away.

Detached mower should be stored in standstill position, so it is supported onto supporting leg and the cutterbar. It is recommended to store the set on paved ground, preferably in roofed places, inaccessible to unauthorized personnel or animals.

At the end of the season the mower should be cleaned, washed and dried. Carefully grease unpainted surfaces and 3-point linkage pins.

After that the following work should be carried out:

- ❑ remove any traces of rust and paint the area affected,
- ❑ check lubrication of intersecting axis gear and cutterbar. If leaks occur, remove them immediately. If water is discovered in the oil, it must be changed, otherwise the gears, bearings and shafts could be damaged,
- ❑ periodically check the mower and secure the moving parts with grease to prevent the mower from rust, which affects the proper functioning of the mower,
- ❑ regularly check hydraulic hoses. In case of damage or expiry replace with new ones. Expiry period should not exceed 5 years.

## 7. LUBRICATION

### 7.1. Cutterbar

Refilling the oil of the cutterbar is done through the inlet **A** (**Fig. 31**). Proper oil level is 4.5÷7 mm from the cutterbar bottom. Oil capacities are shown in tab. 4.

**Tab. 5.** Oil capacities

Model	Oil capacity [l]	Oil type	Lubrication frequency
KDT 180 – 1.80 m	3.5	80W90	Once every 3 seasons (if working intensively more frequently)
KDT 220 S/W – 2.20 m	4.5		
KDT 260 S/W – 2.60 m	5.0		
KDT 300 – 3.00 m	6.0		
KDT 340 – 3.40 m	6.5		

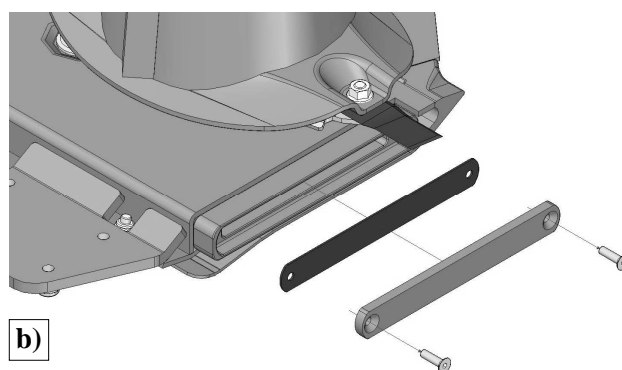
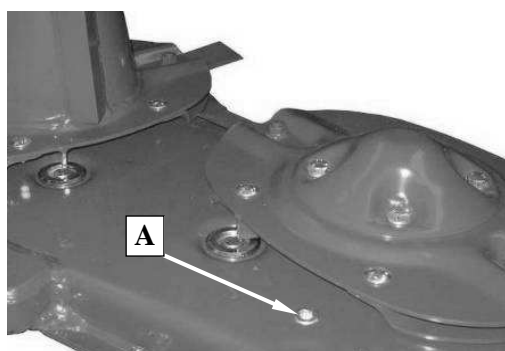

**Fig. 31.** Point of oil inspection a) and manner of oil replacement in cutterbar b)

In order to drain oil out of the cutterbar, firstly lift the mower up onto tractor's links and then dismantle the cutterbar closure as shown on **Fig. 31b** and tilt the cutterbar so, as to enable the old oil to drain. Oil drained out of the cutterbar should be disposed in a proper manner.

### 7.2. Intersecting axis gear

Everyday before starting work please check the oil level and, if needed, please refill after having removed the vent **A** on the top of the gear (**Fig. 32**). The oil level can be checked through the check opening **B** on the side of the gear. Please refill the oil until it is visible in the check opening **B**. The oil capacity: about 1 l.

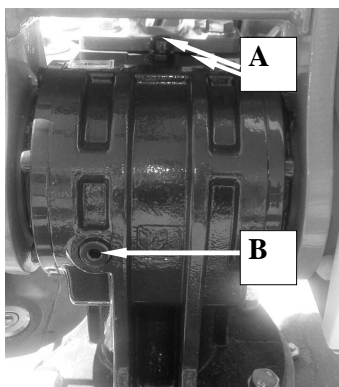

Fig. 32.

Model	Oil capacity [l]	Oil type	Lubrication frequency
All types	1	Transol 680 ÷ 1000 (acc. to ISO 3448 oil viscosity grade : VG-680 – 1000 )	Once every 3 seasons (if working intensively more frequently)

Tab. 6. Oil capacities



**CAUTION:**

The above instructions should be strictly followed. If the discs in the cutterbar rotate loosely, do not worry about the high intersecting axis gear temperature; after long working time it may reach even 100°C.

**7.3. Roller conditioner's gearbox**

Before you check the lubrication of the gearbox, please remove the safety guard. Everyday before starting work please check the oil level and, if needed, please refill after having removed the vent **A** on the top of the gearbox (**Fig. 32**) The oil level can be checked through the check opening **B** on the side of the gear. Please refill the oil until it is visible in the check opening **B**. The oil level: about 0,5 l. Check oil level when the cutterbar is on the ground. Removing the worked oil from the gearbox is done through the outlet **C**.

Tab. 7. Oil capacities

Model	Oil capacity [l]	Oil type – for gearboxes	Lubrication frequency
All models	0.5	80W90	Once every 3 seasons (if working intensively)

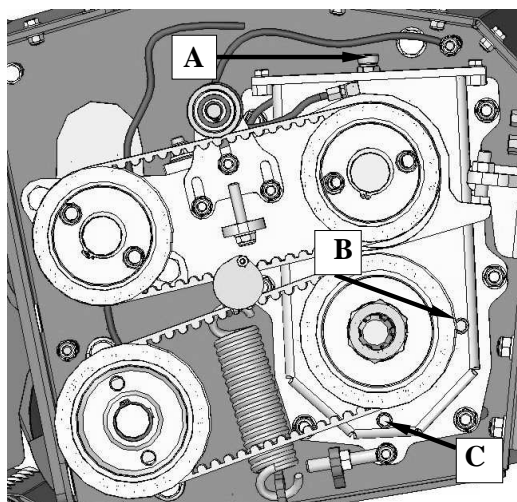

Fig. 33. Roller conditioner's gearbox lubrication points

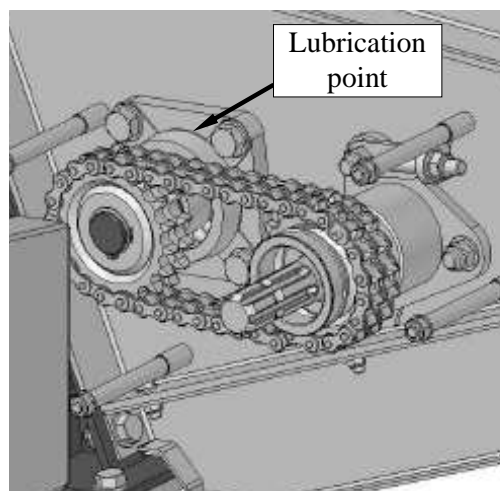
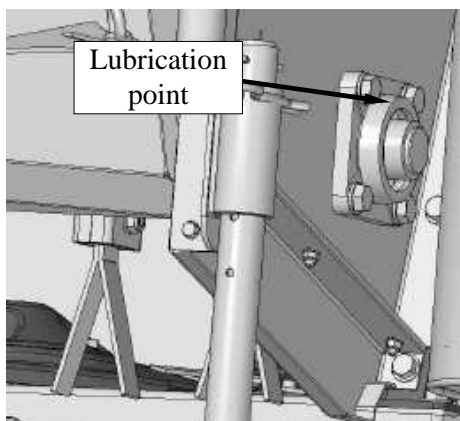
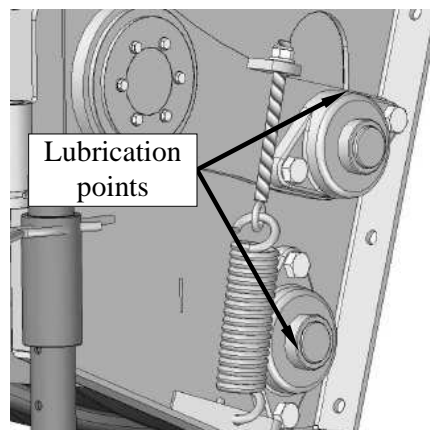

Fig. 34. Bearing lubrication point with LT43 grease



**Fig. 35.** Bearing lubrication point with LT43 grease



**Fig. 36.** Bearing lubrication point with LT43 grease

## 7.4. Bearings and joints

Every 50 mower working hours lubricate tine/roller conditioner's bearings (**Fig. 34, 35, 36**) with **LT43** grease (or other designed to lubricate rolling and slide bearings, that work in  $-30^{\circ}\text{C}$  do  $+130^{\circ}\text{C}$ ) and main joints of the mower (**Fig. 37, 38**) with **STP** grease.

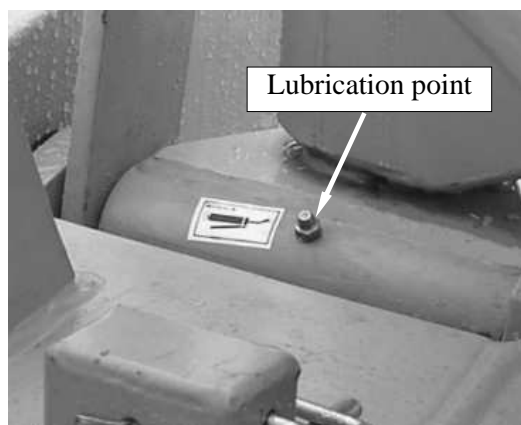

**Fig. 37.** Lubrication point of the suspension with STP grease

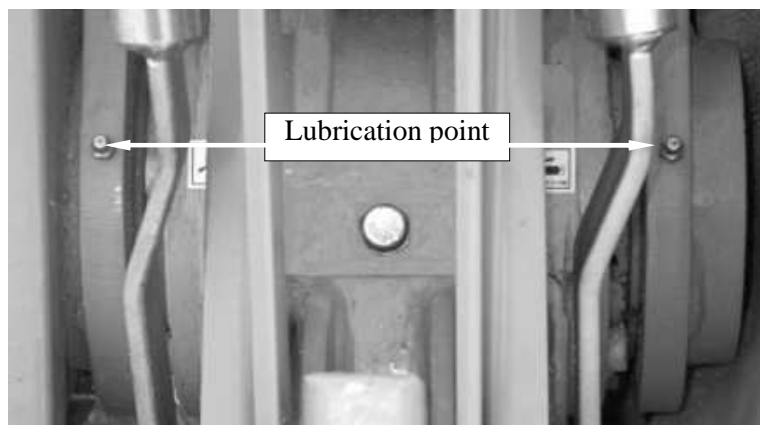

**Fig. 38.** Lubrication point of the suspension with STP grease

## 8. DEFECTS AND THEIR REPAIRS

**Tab. 8.** Defects and their repair

Defect	Reason	Repair	
Mower stops working (partly)– leaves stripes of uncut grass between the discs	1	Lack of knives	Put on knives
	2	Worn knives	Replace knives
	3	Improperly mounted knives (left – right)	Put on knives strictly acc. to instructions
	4	Improper front inclination	Adjust inclination strictly acc. to instructions
	5	Too high PTO rpm (The most frequent mistake)	Reduce PTO rpm (recommended 1600-1800 rpm)
	6	Too low work speed	Speed up to $V \geq 10$ km/h

<b>Defect</b>	<b>Reason</b>	<b>Repair</b>	
Mower stops working (partly)– leaves stripes of uncut grass between the discs	7	Sliding V-belts	
		Too low spring tension – regulate spring tension acc. to instructions	
		Worn V-belts – Replace V-belts	
	8	Damaged tractor's PTO	Repair
	9	Check tractor's PTO if it has 540 E. E stands for economical rpm – around 380 rpm	In that case operate with 1000 PTO rpm but low tractor's rpm – around 1200 rpm
	Mower with either tine or roller conditioner may mow improperly in case of very small grass or after the rain		
The grass is wound on the forming drums	Mowing lying grass without inclination towards the front	Always mow low and fast – inclination towards the front – 4 cm	
Grass blocks the mower – lack of grass flow or the flow is uneven	Too low work speed	Speed up to 10 km/h or more	
	Swath guides are set too narrow	Widen swath guides to the maximum	
Safety device is working often incorrectly without clear reason	Insufficient spring tension	Adjust spring tension acc. to instructions	
	Worn elements of safety device	Replace the safety device	
Mower does not work, even though the drive is transmitted from the tractor	Torn off shaft of intersecting axis gear	Replace intersecting axis gear 023.01.COER	
Mower is blocked	Damaged gears in the cutterbar. Damaged bearings in the disc hub	This repair must be done by SaMASZ service	
Mower's hydraulics does not work	Damaged or dirty hydraulic cylinder and check valve	Replace or clean hydraulic connector and check valve	
	Tractor's hydraulic system is damaged	Check tractor's hydraulic system	
Leaking cylinder	Dirty oil in hydraulic unit of the tractor	Replace oil in hydraulic unit of the tractor (recommended class of cleanliness of oil according to NAS 1638 is minimum 9-10). Purchase repair kit of the cylinder and replace damaged sealings	
Excessive vibration during work	Damaged PTO shaft	Check the condition of PTO shaft and if need be replace	
Oil leak in gear	Not tight assembly	Examine tightness and check oil level.	

## 9. DISASSEMBLY AND WITHDRAWAL FROM USE

### 9.1. Disassembly

Before starting any repair or service the mower should be cleaned and any grass or dirt removed. Carefully check nuts and bolts for correct tension and the pins for wear. Replace as necessary.

When repairing the machine, protect it against losing its stability, which in result may crush the operator, so place the mower on a stable ground and protect its location by means of a protected support leg.

### 9.2. Scrapping

If the mower cannot be repaired anymore, it should be withdrawn from use. For this purpose oil from intersecting axis gear and cutterbar should be drained and delivered to a proper waste treatment company. Clean the mower parts, dismantle and dispose properly of all plastic parts. After that, the mower could be sold to breaker's yard.



**CAUTION:**

Before disassembly the mower should be disconnected from the tractor.

## 10.WARRANTY CARD

### REAR DISC MOWER

	Serial number Date of manufacture Manufacturer's stamp QC signature
--	--

	Date of purchase Dealer's stamp Dealer's signature
--	--

The product quality has been checked and meets the required standards and regulations and is permitted for use.



**CAUTION:**

A warranty card without the required information or with corrected or illegible information – **is invalid.**

## 11.WARRANTY TERMS

### 11.1. Warranty claims procedures

1. The manufacturer guarantees its products against faults in materials or production.
2. The warranty period is for two years from the date of sale to the purchaser, stated above.
3. Any repair which is subject to warranty should be carried out by an authorised SaMASZ dealer. Upon completion of the repair the dealer must submit a warranty claim within 14 days.
4. Warranty claims regarding replacing of the product or repayment are considered within 14 days by the manufacturer.
5. The following cases are not covered by warranty:
  - a) **wearing parts: mowing discs, sliding skids, intersecting axis gears and parts inside the gearboxes, bushings and sliding elements, joints, knife holders, cutting knives, V-belts, silide bushings Pcw, chain gears, drive chain, conditioner's tines and rollers, roller cinditioner's rubbers, bearings, safety curtains, conveyor's belts, swath guide's rubbers, connective elements, etc.**  
**These repairs may be done only at purchaserer's cost.**
  - b) **use for any other purpose than those described in the operator's manual,**
  - c) **operation on stoney fields and its results: damage of tine conditioner's shaft, discs, bending of cutterbar (stone with its diameter of 140 mm will not move between the discs and conditioner's shaft),**
  - d) **running into any obstacle,**
  - e) **too fast lowering of the cutterbar to the ground,**
  - f) **transport and accidental damage,**
  - g) **breaking, damage of tine conditioner's shaft.**
6. The Purchaser bears the costs of technical estimation - when the manufacturer finds that a claimed product is free of defects and a technical report will confirm that.
7. The manufacturer has the right to cancel a warranty in the following cases:
  - a) **interference of the interior of the mower, changes of its mechanical design or intentional damages, bending parts of the mower and so on.**
  - b) **operating with only 1 knife on the disc or without disc cover plates.**
  - c) **damage caused by accidents, running into obstacles or other events, for which the warrantor is not responsible,**
  - d) **using of different knives - not original SaMASZ knives,**
  - e) **regulating safety breakaway device spring (Fig. 14) not in accordance with the instructions described in this operator's manual,**
  - f) **lack of needed records in the warranty card or filling in the warranty card independently,**
  - g) **use of the mower not in accordance with operator's manual or for incorrect purpose.**
8. Manufacturer can break the service agreement with immediate effect when the user do not pay receivables according to that agreement in a timely manner and the delay in payment is longer than 30 days from maturity date. Breaking the service agreement caused by the user makes simultaneous breaching of the warranty.
9. Manufacturer does not take compensation responsibility for the loss caused by breakdown of the machine during work.





**CAUTION:**

Please ask your dealer to complete and return the warranty card, otherwise you may lose your warranty rights.



**CAUTION:**

The warranty card is valid only when there are the following information: address, date and place of purchase, mower type and invoice number.



**CAUTION:**

When the warranty expires, repairs can be done for a payment by the entitled repair shops pointed by the dealer. The dealer is obliged to indicate them.



**CAUTION:**

The manufacturer reserves the right to alter technical design and specification without prior notice and without liability.



**CAUTION:**

The SaMASZ Company is continually working on improvement and development of all types and models of mowers. For this reason the form, accessories and technology of delivered products can change. No claims can be made based on the data, illustrations or descriptions contained in this manual or the spare parts catalogue.

## 11.2. Warranty repairs record

Repairs description and changed spare parts:

Date, stamp and signature of repair shop.

Date, stamp and signature of repair shop.

Date, stamp and signature of repair shop.